

BEDDING CLASSES

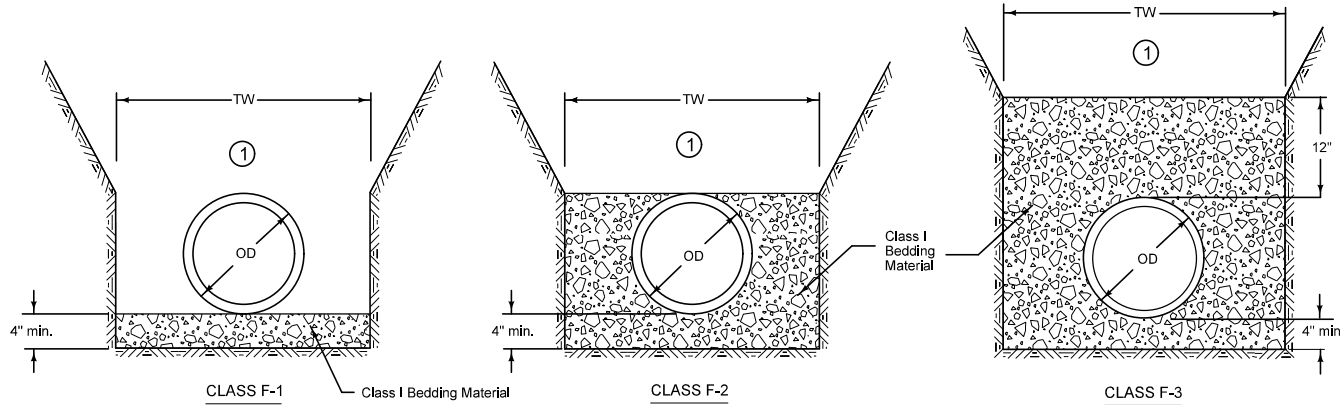

- ① Place remainder of bedding and backfill materials as specified in the contract documents.
- ② Minimum depth of bury 12 inches or as specified by the manufacturer.

ALLOWABLE BEDDING CLASSES

PIPE MATERIAL	STORM SEWER	SANITARY SEWER
Ductile Iron	F-1, F-2, F-3	F-1, F-2, F-3
HDPE	F-2, F-3	Not allowed
Polypropylene	F-2, F-3	F-3
PVC	F-2, F-3	F-3

Key

OD = Outside diameter of pipe
 TW = Trench width at top of pipe;
 Min. = OD+18 Inches OR 1.25xOD+12 Inches
 (whichever is greater)

ALLOWABLE BURY DEPTH ②

PVC PIPE

Pipe Diameter (in)	ASTM D 3034			ASTM F 679	ASTM F 949	ASTM F 1803	ASTM D 2680
	Solid Wall			Solid Wall	Corrug. Exterior	Closed Profile	Composite (Truss Type)
	SDR 23.5	SDR 26	SDR 35	SDR 35			
8	30'	28'	24'	---	24'	---	32'
10	30'	28'	24'	---	24'	---	32'
12	30'	28'	24'	---	24'	---	32'
15	30'	28'	24'	---	24'	---	32'
18	---	---	---	24'	24'	---	---
21	---	---	---	24'	24'	24'	---
24	---	---	---	24'	24'	24'	---
27	---	---	---	24'	---	24'	---
30	---	---	---	24'	24'	24'	---
33	---	---	---	24'	---	---	---
36	---	---	---	24'	24'	24'	---
42	---	---	---	24'	---	24'	---
48	---	---	---	24'	---	24'	---
54	---	---	---	---	---	24'	---
60	---	---	---	---	---	24'	---

DUCTILE IRON, AWWA C151, CLASS 52

Pipe Diameter (in)	Class F-1 Bedding	Class F-2 Bedding	Class F-3 Bedding
4	40'	40'	40'
6	40'	40'	40'
8	40'	40'	40'
10	40'	40'	40'
12	37'	40'	40'
14	31'	40'	40'
16	28'	37'	40'
18	25'	34'	40'
20	23'	32'	40'
24	20'	29'	38'
30	18'	23'	31'
36	18'	22'	30'
42	17'	21'	29'
48	16'	19'	27'
54	16'	19'	27'

HDPE PIPE

Pipe Diameter (in)	AASHTO M 294
12	8'
15	9'
18	9'
24	9'
30	9'
36	9'
42	8'
48	8'
54	8'
60	8'

POLYPROPYLENE PIPE

Pipe Diameter (in)	ASTM F 2764
12	24'
15	25'
18	22'
24	20'
30	22'
36	21'
42	22'
48	23'
54	21'
60	21'

FIGURE 3010.103 SHEET 1 OF 1

		REVISION
		3 04-16-19
FIGURE 3010.103	STANDARD ROAD PLAN	SW-103
SHEET 1 of 1		
REVISIONS: Removed ASTM F 2736 from Polypropylene Pipe table. Changed Class 1 to Class I in the CLASS F-2 and CLASS F-3 details.		
SUDAS DIRECTOR		DESIGN METHODS ENGINEER
FLEXIBLE GRAVITY PIPE TRENCH BEDDING		