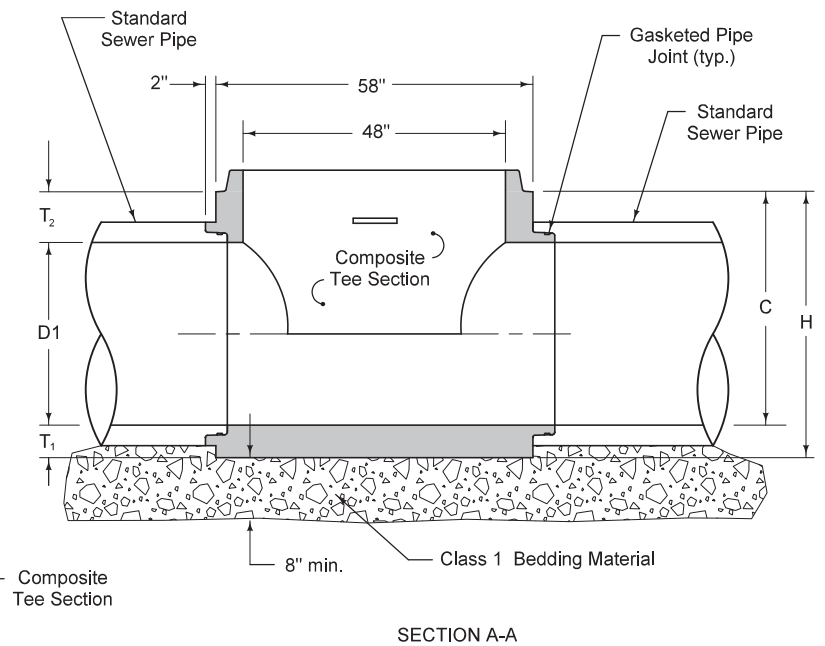
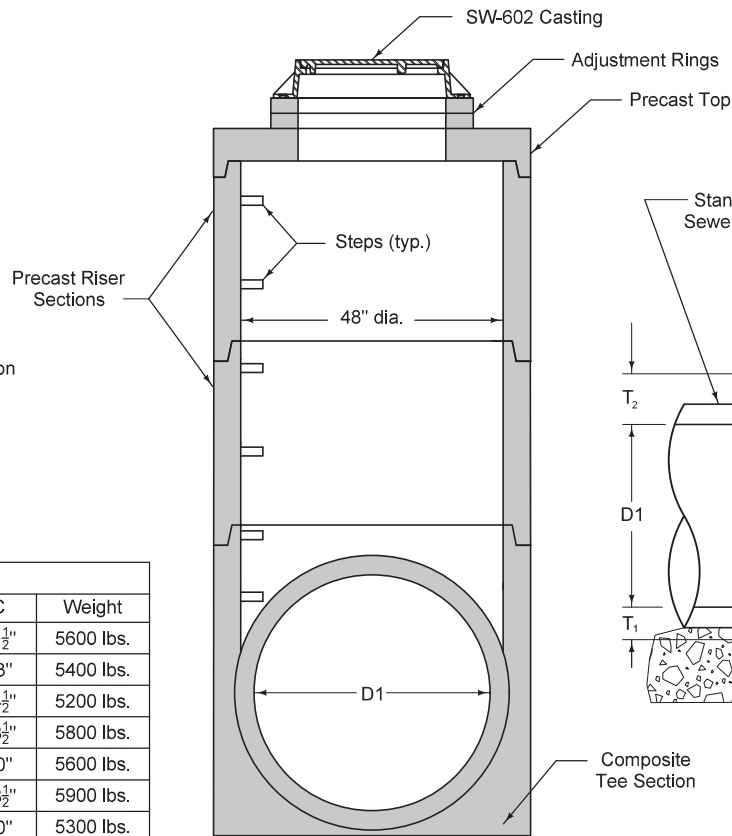
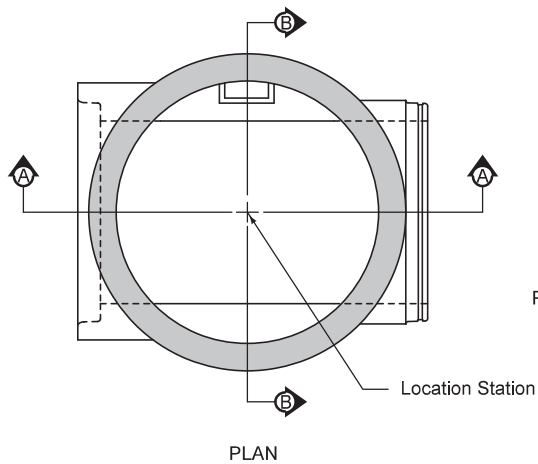

FIGURE 6010.405 SHEET 1 OF 2

SUDAS	IOWADOT	REVISION
		2 10-17-17
FIGURE 6010.405	STANDARD ROAD PLAN	SW-405
		SHEET 1 of 2
REVISIONS: Changed title from TEE-SECTION STORM SECTION MANHOLE to TEE-SECTION STORM SEWER MANHOLE.		
<i>Paul D. Wigand</i> SUDAS DIRECTOR		<i>Brian Smith</i> DESIGN METHODS ENGINEER
TEE-SECTION STORM SEWER MANHOLE		



COMPOSITE TEE DIMENSIONS						
Size	D1	H	T ₁	T ₂	C	Weight
48" on 12"	12"	50"	8½"	29½"	41½"	5600 lbs.
48" on 15"	15"	50"	7"	28"	43"	5400 lbs.
48" on 18"	18"	50"	5½"	26½"	44½"	5200 lbs.
48" on 21"	21"	48"	9½"	17½"	38½"	5800 lbs.
48" on 24"	24"	48"	8"	16"	40"	5600 lbs.
48" on 27"	27"	48"	9½"	11½"	38½"	5900 lbs.
48" on 30"	30"	48"	8"	10"	40"	5300 lbs.
48" on 33"	33"	54"	9½"	11½"	44½"	6600 lbs.
48" on 36"	36"	54"	8"	10"	46"	6100 lbs.

SECTION B-B

SECTION A-A

COMPOSITE TEE

Alternate to standard tee with eccentric reducer (for pipes 36" and smaller).

FIGURE 6010.405 SHEET 2 OF 2

SUDAS IOWADOT	REVISION	2	10-17-17
	FIGURE 6010.405	STANDARD ROAD PLAN	SW-405
			SHEET 2 of 2
<small>REVISIONS: Changed title from TEE-SECTION STORM SECTION MANHOLE to TEE-SECTION STORM SEWER MANHOLE.</small>			
<i>Paul D. Wigand</i> <small>SUDAS DIRECTOR</small>		<i>Brian Smith</i> <small>DESIGN METHODS ENGINEER</small>	
TEE-SECTION STORM SEWER MANHOLE			