

TYPE E
Two-piece fixed casting

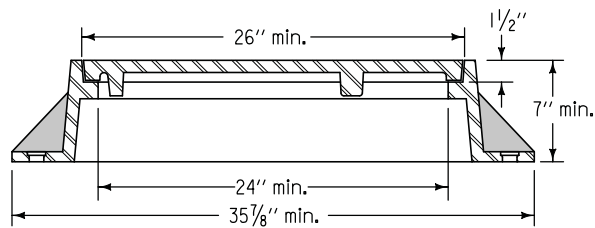

TYPICAL SECTION

TYPE F
Three-piece floating casting

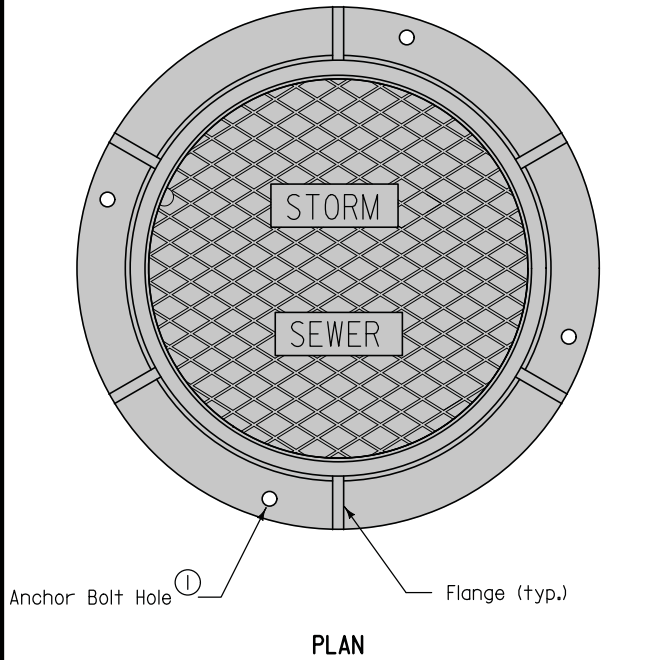
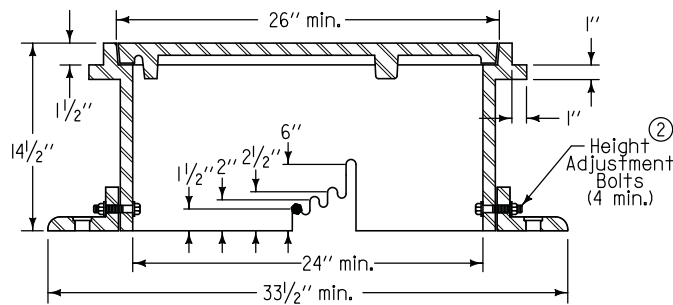
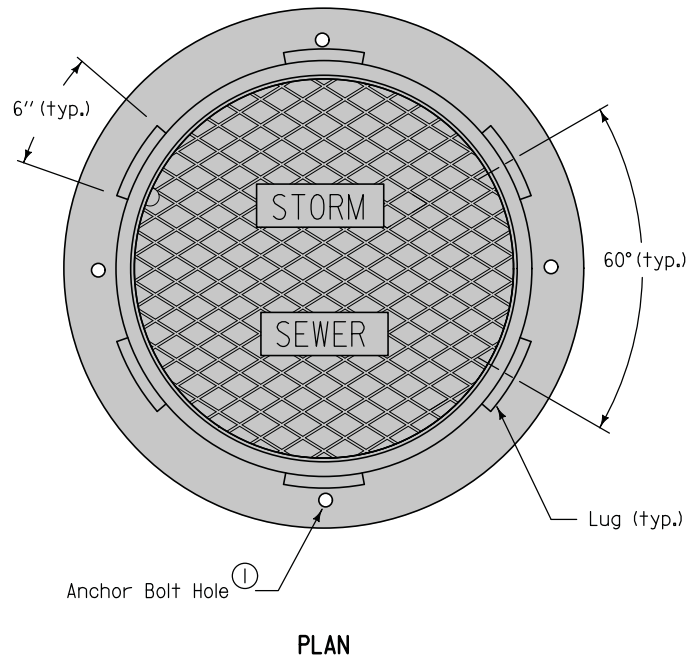

TYPICAL SECTION

Frame Notes:
Size and spacing of lugs and flanges may vary.

Cover Notes:
Roughness pattern and text styles may vary.
Minimum one concealed pickhole.

- ① When the contract documents require the frame to be attached to the structure, drill four 7/8" diameter holes or slots, equally spaced around frame.
- ② Remove bolts upon completion of paving.

FIGURE 6010.602 SHEET 1 OF 2

		REVISION
		1 10-20-09
FIGURE 6010.602 STANDARD ROAD PLAN		SW-602 SHEET 1 of 2
REVISIONS: Changed note 1 and added shading.		
SUDAS DIRECTOR		DESIGN METHODS ENGINEER
CASTINGS FOR STORM SEWER MANHOLES		

TYPE G
Two-piece fixed casting

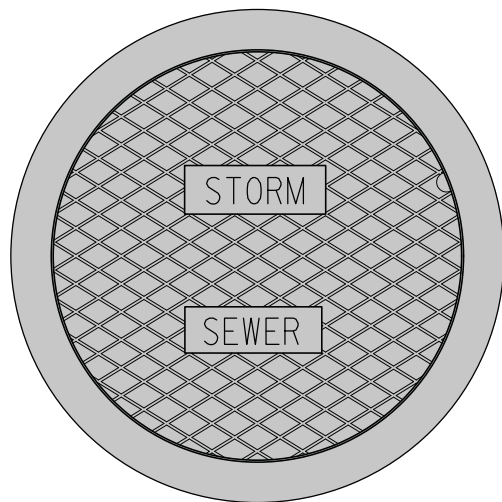

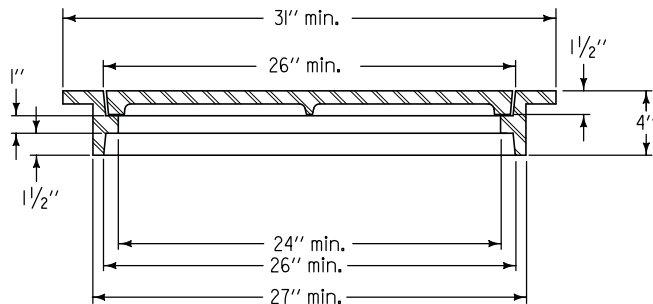

PLAN



TYPICAL SECTION

FIGURE 6010.602 SHEET 2 OF 2

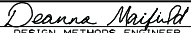
 SUDAS	 Iowa Department of Transportation	REVISION	
		1	10-20-09
FIGURE 6010.602 STANDARD ROAD PLAN		SW-602	
		SHEET 2 of 2	
REVISIONS: Changed note 1 and added shading.			
 SUDAS DIRECTOR		 DESIGN METHODS ENGINEER	
CASTINGS FOR STORM SEWER MANHOLES			