

BEDDING CLASSES

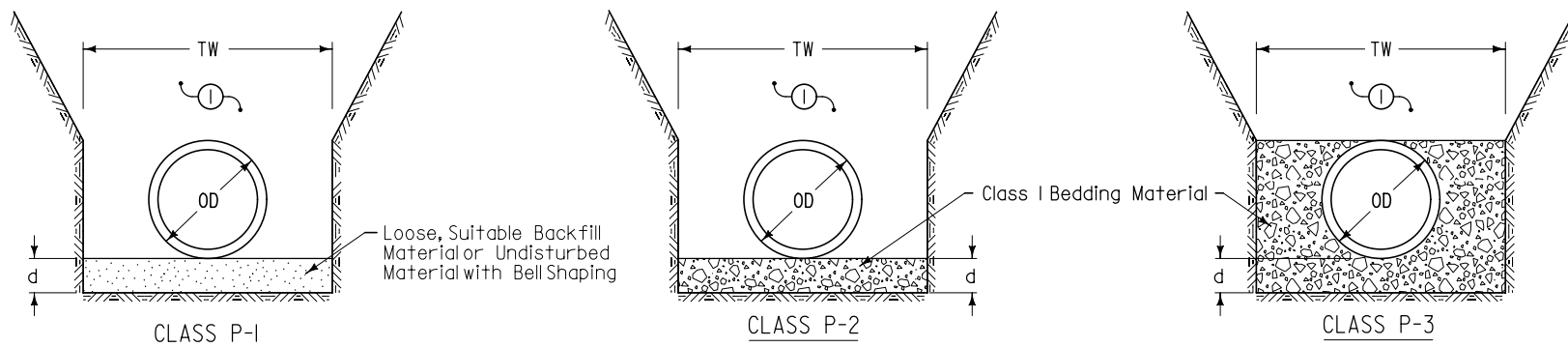

ALLOWABLE BURY DEPTH

DUCTILE IRON, AWWA C151, CLASS 52

Pipe Diameter (inches)	Class P-1 Bedding	Class P-2 Bedding	Class P-3 Bedding
4	40'	40'	40'
6	40'	40'	40'
8	40'	40'	40'
10	36'	40'	40'
12	31'	40'	40'
14	26'	40'	40'
16	23'	37'	40'
18	20'	34'	40'
20	18'	32'	40'
24	16'	29'	38'
30	13'	23'	31'
36	13'	22'	30'
42	13'	21'	29'
48	13'	19'	27'
54	13'	19'	27'

PVC, AWWA C900 & C905, DRI8

Pipe Diameter (inches)	Class P-1 Bedding	Class P-2 Bedding	Class P-3 Bedding
4	19'	23'	40'
6	19'	23'	40'
8	19'	23'	40'
10	19'	23'	40'
12	19'	23'	40'
14	19'	23'	40'
16	19'	23'	40'
18	19'	23'	40'
20	19'	23'	40'
24	19'	23'	40'

① Place remainder of bedding and backfill material as specified in the contract documents.

Key

- OD = Outside diameter of pipe
- TW = Trench width at top of pipe:
Min. = OD+18 inches OR 1.25xOD+12 inches
(whichever is greater)
- d = Depth of bedding material below pipe:
Min. = OD/8 OR 4 inches
(whichever is greater)

FIGURE 3010.104 SHEET 1 OF 1

		REVISION
		NEW 04-21-09
FIGURE 3010.104	STANDARD ROAD PLAN	SW-104
		SHEET 1 of 1
REVISIONS: New.		
SUDAS DIRECTOR		DESIGN METHODS ENGINEER
PRESSURE PIPE TRENCH BEDDING		