

For joint details, see PV-101.

- ① Ballast meeting Railroad specifications may be substituted for modified subbase.
- ② #5 Bars at 12" centers located at half of the pavement thickness. Wire tie at all intersections with other bars. Lap a minimum of 1 foot when necessary and securely wire tie.
- ③ #5 Bars x (Approach Width - 4").
- ④ Outlet subdrain into ditch or storm sewer. See DR-303 and DR-306. Slope subdrain to drain.
- ⑤ Slope according to AREMA specifications

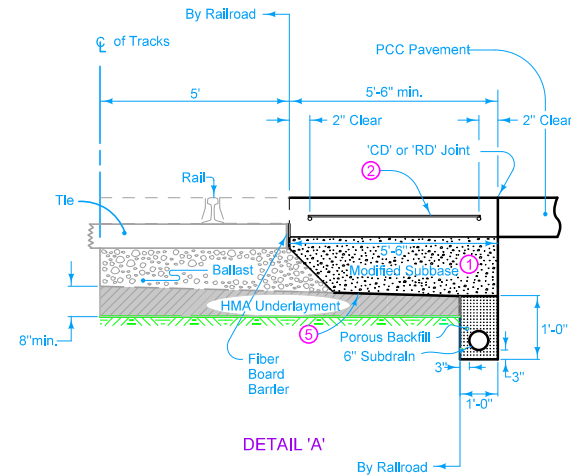
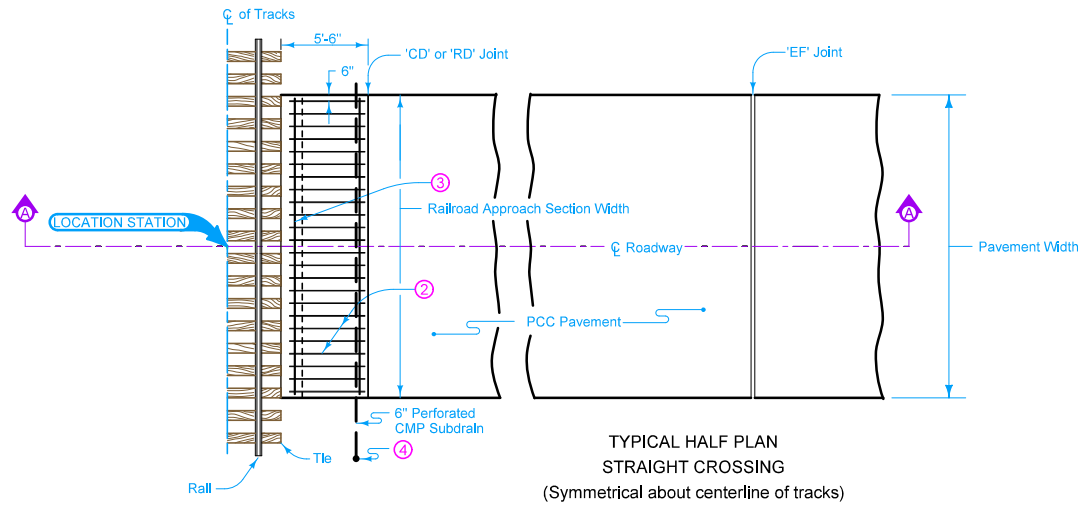

Possible Contract Item:
Railroad Approach Section, P.C.C.

Possible Tabulation:
112-3

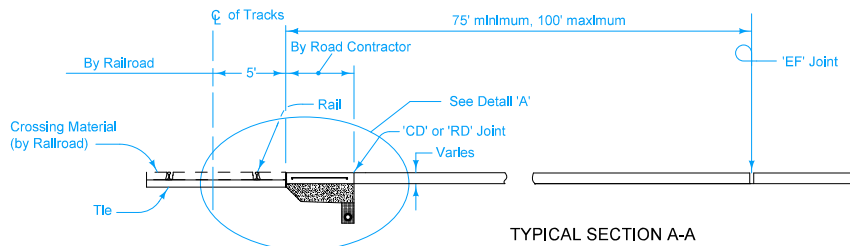

IOWA DOT	REVISION	
	2	10-17-17
STANDARD ROAD PLAN		PV-106
		SHEET 1 of 2

REVISIONS: Changed DR-304 to DR-306.

Brian Smith
APPROVED BY DESIGN METHODS ENGINEER

**PCC RAILROAD
APPROACH SECTION**

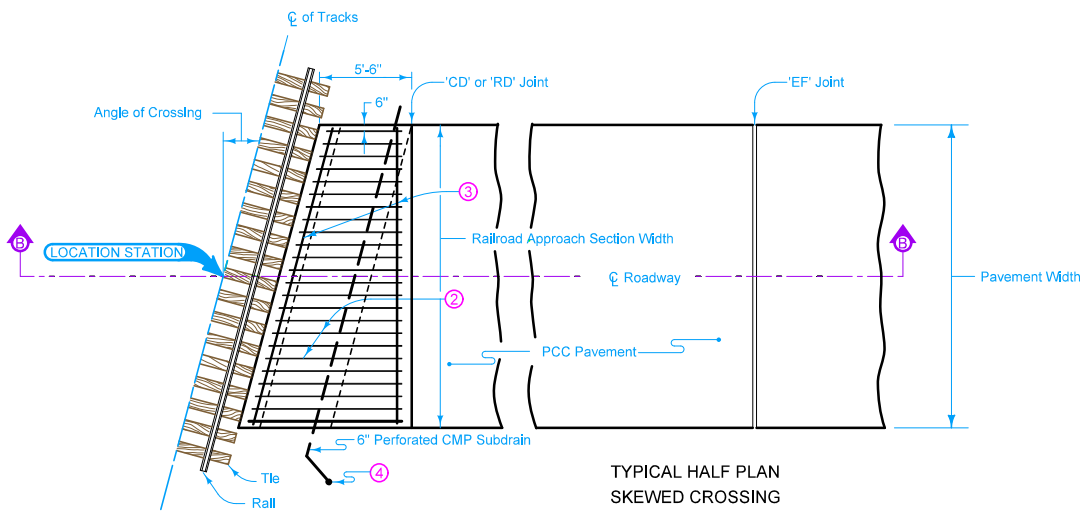

TYPICAL HALF PLAN
SKEWED CROSSING
(Symmetrical about centerline of tracks)

- ① Ballast meeting Railroad specifications may be substituted for modified subbase.
- ② #5 Bars at 12" centers located at half of the pavement thickness. Wire tie at all intersections with other bars. Lap a minimum of 1 foot when necessary and securely wire tie.
- ③ #5 Bars x (Approach Width - 4").
- ④ Outlet subdrain into ditch or storm sewer. See DR-303 and DR-306. Slope subdrain to drain.
- ⑤ Slope according to AREMA specifications

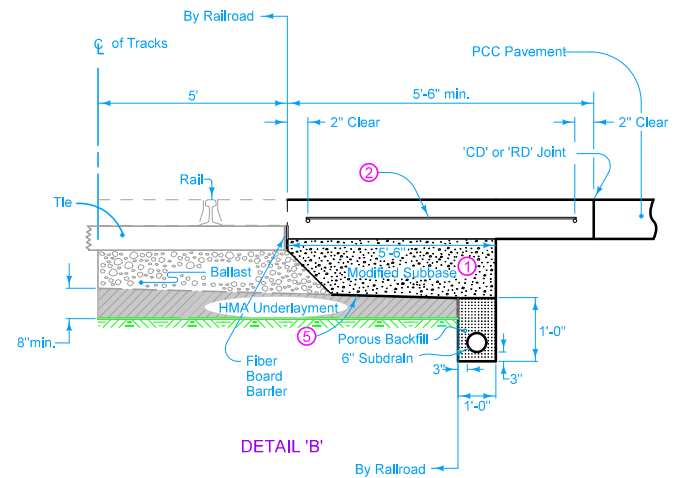

DETAIL 'B'

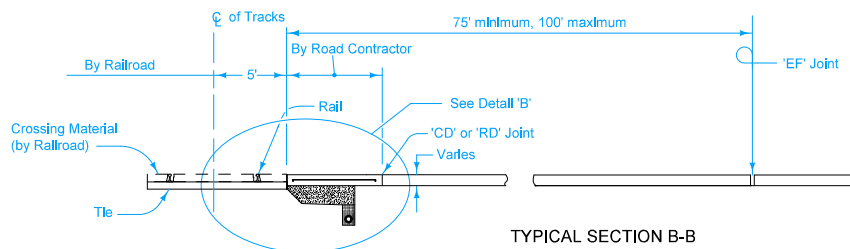

TYPICAL SECTION B-B

IOWA DOT	REVISION	
	2	10-17-17
STANDARD ROAD PLAN		PV-106
REVISIONS: Changed DR-304 to DR-306.		SHEET 2 of 2

Brian Smith
APPROVED BY DESIGN METHODS ENGINEER

**PCC RAILROAD
APPROACH SECTION**