

ESTIMATE OF QUANTITIES - FLUME BELL JOINTS

| JUNCTION BELL JOINT | | 10' x 4' | | 10' x 5' | | 10' x 6' | | 10' x 7' | | 10' x 8' | | 10' x 9' | | 10' x 10' | | 10' x 11' | | 10' x 12' | | | | | | | | | | | |
|---------------------|---------------|----------|-----|----------|--------|----------|---------|----------|-----|----------|--------|----------|--------|-----------|-----|-----------|--------|-----------|--------|--------|----|--------|-----|----|--------|-----|----|--------|-----|
| BAR | LOCATION | SHAPE | NO. | LENGTH | WEIGHT | NO. | LENGTH | WEIGHT | NO. | LENGTH | WEIGHT | NO. | LENGTH | WEIGHT | NO. | LENGTH | WEIGHT | NO. | LENGTH | WEIGHT | | | | | | | | | |
| 6x1 | WALLS & FLOOR | | 4 | 22'-11" | 138 | 4 | 22'-11" | 138 | 4 | 23'-1" | 139 | 4 | 23'-1" | 139 | 4 | 23'-3" | 140 | 4 | 23'-5" | 141 | | | | | | | | | |
| 6x3 | WALLS VERT. | | 8 | 4'-4" | 52 | 8 | 5'-4" | 64 | 8 | 6'-4" | 76 | 8 | 7'-4" | 88 | 8 | 8'-4" | 100 | 8 | 9'-4" | 112 | 8 | 10'-4" | 124 | 8 | 11'-4" | 136 | 8 | 12'-4" | 148 |
| 6y1 | WALLS HORIZ. | | 12 | 7'-8" | 138 | 14 | 7'-8" | 161 | 16 | 7'-8" | 184 | 18 | 7'-8" | 207 | 20 | 7'-10" | 235 | 22 | 7'-10" | 259 | 24 | 7'-10" | 282 | 26 | 7'-11" | 309 | 28 | 8'-1" | 340 |
| 6y2 | FLOOR VERT. | | 12 | 9'-1" | 164 | 12 | 9'-1" | 164 | 12 | 9'-1" | 164 | 12 | 9'-1" | 164 | 12 | 9'-1" | 164 | 12 | 9'-1" | 164 | 12 | 9'-1" | 164 | 12 | 9'-1" | 164 | 13 | 9'-1" | 177 |
| 6z1 | FLOOR VERT. | | 12 | 4'-1" | 74 | 12 | 4'-1" | 74 | 12 | 4'-1" | 74 | 12 | 4'-1" | 74 | 12 | 4'-1" | 74 | 12 | 4'-1" | 74 | 12 | 4'-1" | 74 | 12 | 4'-1" | 74 | 13 | 4'-1" | 80 |
| TOTAL WEIGHT (LBS.) | | | | | 566 | | | 601 | | | 636 | | | 671 | | | 712 | | | 748 | | | 783 | | | 823 | | | 866 |
| FOOTING | | | | | 2.8 | | | 2.8 | | | 2.8 | | | 2.8 | | | 2.9 | | | 2.9 | | | 2.9 | | | 2.9 | | | 2.9 |
| CONCRETE (CY) | | | | | 1.3 | | | 1.6 | | | 1.9 | | | 2.1 | | | 2.4 | | | 2.7 | | | 3.0 | | | 3.3 | | | 3.6 |
| TOTAL | | | | | 4.1 | | | 4.4 | | | 4.7 | | | 4.9 | | | 5.3 | | | 5.6 | | | 5.9 | | | 6.2 | | | 6.5 |

| CHUTE BELL JOINT | | 10' x 4' | | 10' x 5' | | 10' x 6' | | 10' x 7' | | 10' x 8' | | 10' x 9' | | 10' x 10' | | 10' x 11' | | 10' x 12' | | | | | | | | | | | |
|---------------------|---------------|----------|-----|----------|--------|----------|--------|----------|-----|----------|--------|----------|---------|-----------|-----|-----------|--------|-----------|--------|--------|----|--------|-----|----|--------|-----|----|-------|-----|
| BAR | LOCATION | SHAPE | NO. | LENGTH | WEIGHT | NO. | LENGTH | WEIGHT | NO. | LENGTH | WEIGHT | NO. | LENGTH | WEIGHT | NO. | LENGTH | WEIGHT | NO. | LENGTH | WEIGHT | | | | | | | | | |
| 6x2 | WALLS & FLOOR | | 4 | 23'-8" | 142 | 4 | 25'-2" | 151 | 4 | 22'-11" | 138 | 4 | 22'-11" | 138 | 4 | 23'-1" | 139 | 4 | 23'-1" | 139 | 4 | 23'-3" | 140 | 4 | 23'-5" | 141 | | | |
| 6x4 | WALLS VERT. | | -- | -- | -- | -- | -- | -- | 8 | 4'-0" | 48 | 8 | 4'-9" | 57 | 8 | 5'-6" | 66 | 8 | 6'-3" | 75 | 8 | 7'-0" | 84 | 8 | 7'-9" | 93 | 8 | 8'-6" | 102 |
| 6y3 | WALLS HORIZ. | | 8 | 7'-8" | 92 | 10 | 7'-8" | 115 | 12 | 7'-8" | 138 | 12 | 7'-8" | 138 | 14 | 7'-10" | 165 | 16 | 7'-10" | 188 | 18 | 7'-10" | 212 | 18 | 7'-11" | 214 | 20 | 8'-1" | 243 |
| 6y4 | FLOOR VERT. | | 12 | 9'-0" | 162 | 12 | 9'-0" | 162 | 12 | 9'-0" | 162 | 12 | 9'-0" | 162 | 12 | 9'-0" | 162 | 12 | 9'-0" | 162 | 12 | 9'-0" | 162 | 12 | 9'-0" | 162 | 13 | 9'-0" | 176 |
| 6z1 | FLOOR VERT. | | 12 | 4'-1" | 74 | 12 | 4'-1" | 74 | 12 | 4'-1" | 74 | 12 | 4'-1" | 74 | 12 | 4'-1" | 74 | 12 | 4'-1" | 74 | 12 | 4'-1" | 74 | 12 | 4'-1" | 74 | 13 | 4'-1" | 80 |
| TOTAL WEIGHT (LBS.) | | | | | 470 | | | 502 | | | 560 | | | 569 | | | 606 | | | 638 | | | 671 | | | 683 | | | 742 |
| FOOTING | | | | | 2.8 | | | 2.8 | | | 2.8 | | | 2.8 | | | 2.8 | | | 2.8 | | | 2.8 | | | 2.8 | | | 2.9 |
| CONCRETE (CY) | | | | | 0.8 | | | 1.0 | | | 1.2 | | | 1.4 | | | 1.6 | | | 1.8 | | | 2.0 | | | 2.3 | | | 2.5 |
| TOTAL | | | | | 3.6 | | | 3.8 | | | 4.0 | | | 4.2 | | | 4.4 | | | 4.6 | | | 4.8 | | | 5.1 | | | 5.4 |

BENT BAR DETAILS

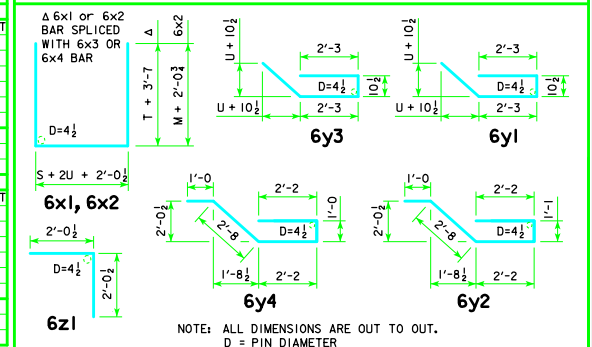

BARREL & CHUTE DIMENSIONS

| S x H | M | T | U | BT | BU |
|-----------|-------|-------|--------|-------|--------|
| 10' x 4' | 3'-0" | 1'-1" | 0'-9" | 1'-0" | 0'-9" |
| 10' x 5' | 3'-9" | 1'-1" | 0'-9" | 1'-0" | 0'-9" |
| 10' x 6' | 4'-6" | 1'-1" | 0'-9" | 1'-0" | 0'-9" |
| 10' x 7' | 5'-3" | 1'-1" | 0'-9" | 1'-0" | 0'-9" |
| 10' x 8' | 6'-0" | 1'-1" | 0'-10" | 1'-0" | 0'-9" |
| 10' x 9' | 6'-9" | 1'-1" | 0'-10" | 1'-0" | 0'-9" |
| 10' x 10' | 7'-6" | 1'-1" | 0'-10" | 1'-0" | 0'-10" |
| 10' x 11' | 8'-3" | 1'-1" | 0'-11" | 1'-0" | 0'-11" |
| 10' x 12' | 9'-0" | 1'-1" | 1'-0" | 1'-0" | 1'-0" |

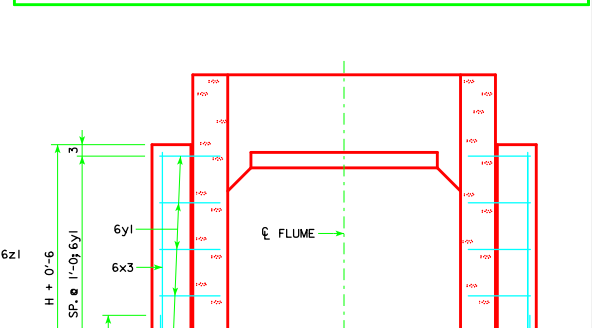
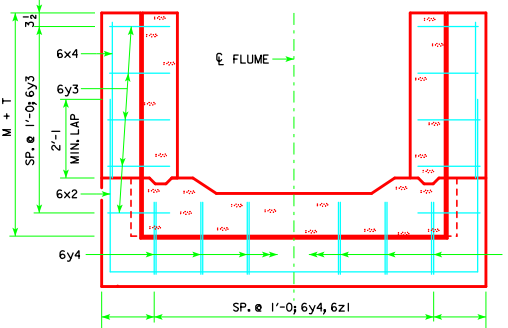
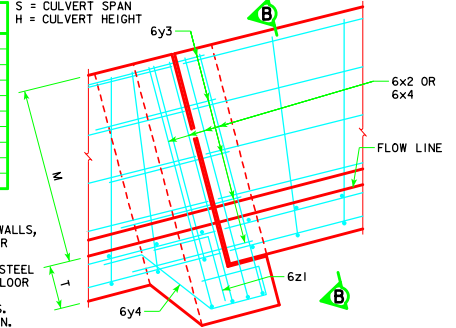

- NOTES:**
- DIMENSIONS AND QUANTITIES SHOWN BASED ON 'U' FLUME WALLS, 'BU' BARREL WALLS, 'T' FLUME FLOOR AND 'BT' BARREL FLOOR THICKNESSES.
 - CHANGE LENGTHS OF BARS 6x1 AND ADJUST REINFORCING STEEL AND CONCRETE QUANTITIES ACCORDINGLY FOR WALL AND FLOOR THICKNESSES OTHER THAN SHOWN.
 - FLOOR BARS m1 ARE TO BE SHORTENED 6" AT BELL JOINTS.
 - SEE STANDARD SHEET RCF-01-12 FOR GENERAL INFORMATION.

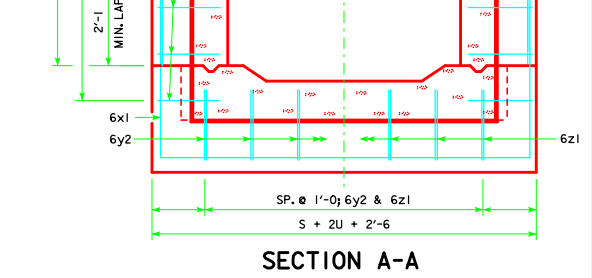
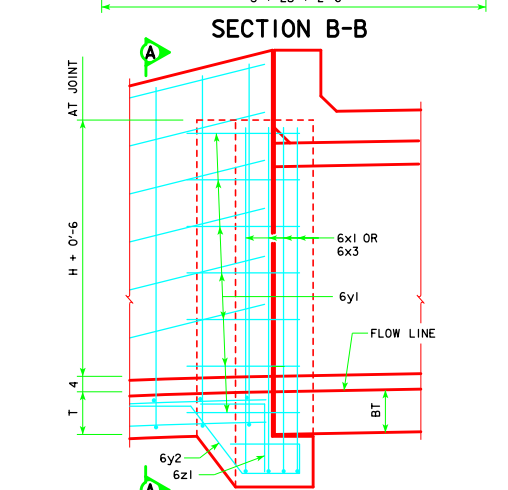
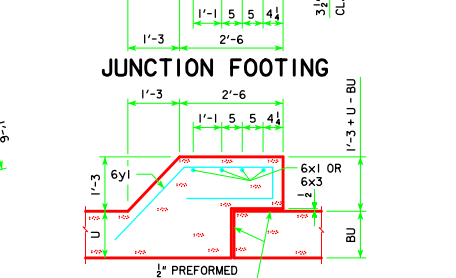
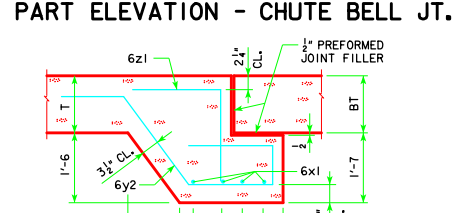
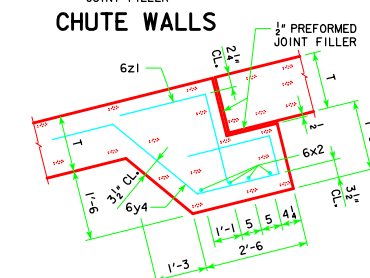
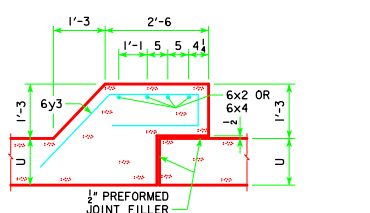

| | | | | |
|----------------------|--|---|------------------|---------------------------------|
| LATEST REVISION DATE | IOWA Department of Transportation Highway Division STANDARD DESIGN REINFORCED CONCRETE BOX CULVERTS APRIL, 2012 | FLUME BELL JOINT DETAILS 10' SPAN | FBJ-04-12 | |
| | | | | APPROVED BY BRIDGE ENGINEER |
| | | | | APPROVED BY BRIDGE ENGINEER |

ENGLISH(DIMENSIONS).DGN - FBJ-04-12 - THIS SHEET ISSUED 04-12