

TYPE E
Two-piece fixed casting

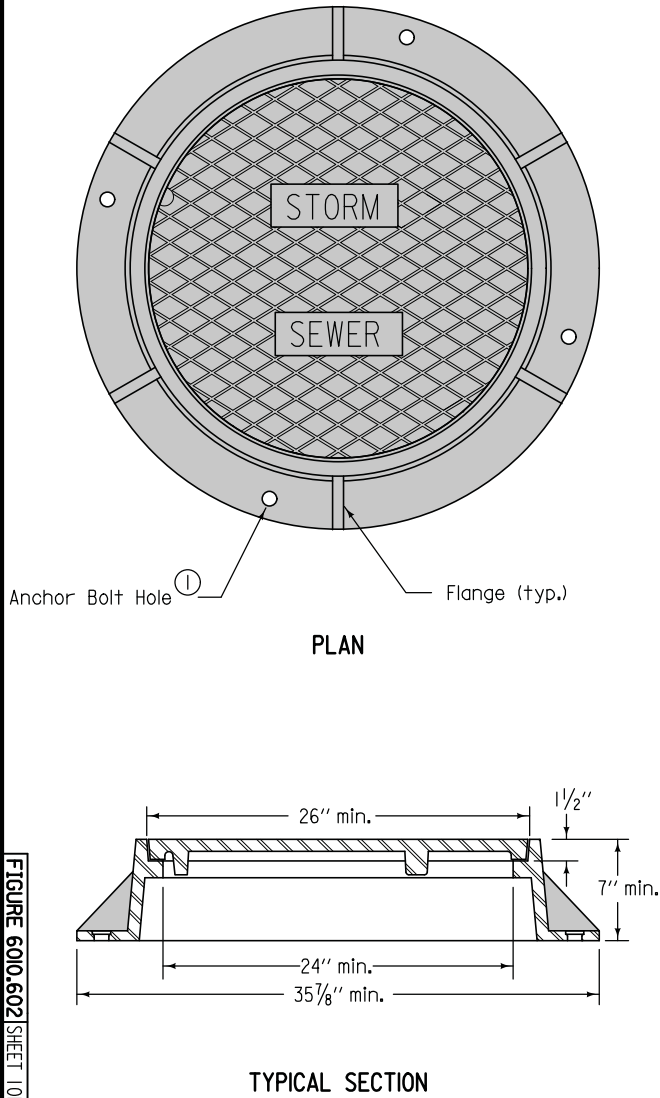

TYPE F
Three-piece floating casting

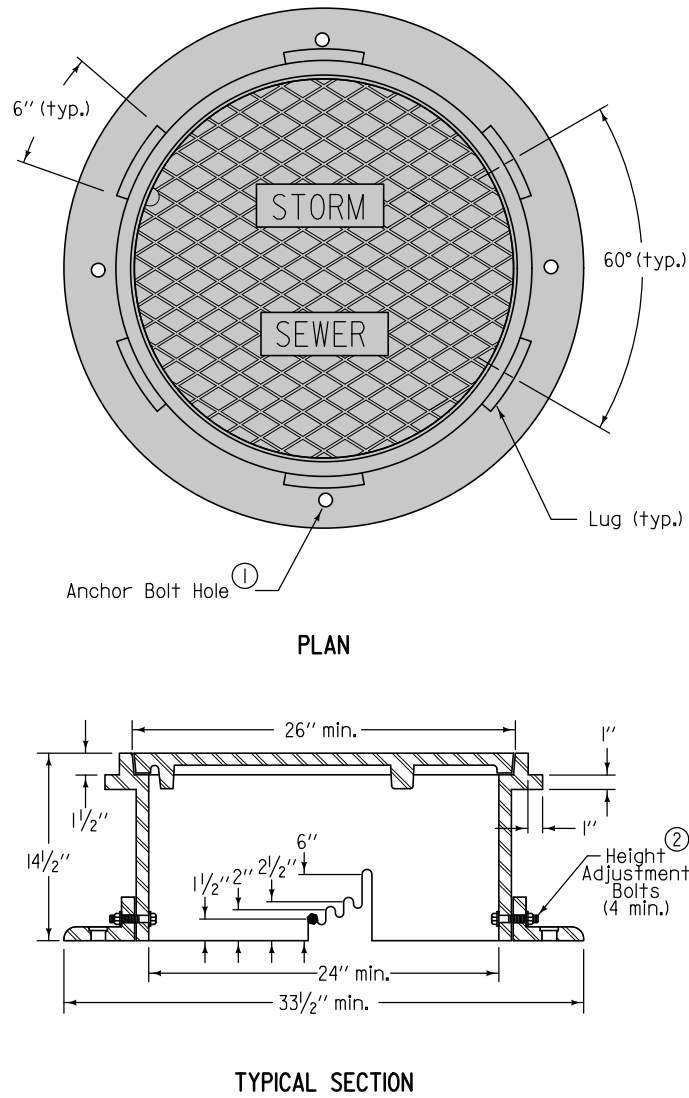

Frame Notes:
Size and spacing of lugs and flanges may vary.

Cover Notes:
Roughness pattern and text styles may vary.
Minimum one concealed pickhole.

- ① When the contract documents require the frame to be attached to the structure, drill four 7/8" diameter holes or slots, equally spaced around frame.
- ② Remove bolts upon completion of paving.

FIGURE 6010.602 SHEET 1 OF 2

SUDAS	Iowa Department of Transportation	REVISION
		2 04-15-14
FIGURE 6010.602 STANDARD ROAD PLAN		SW-602 SHEET 1 of 2
REVISIONS: Changed dimensions on page 2.		
<i>Paul D. Wigand</i> SUDAS DIRECTOR		<i>Brian Smith</i> DESIGN METHODS ENGINEER
CASTINGS FOR STORM SEWER MANHOLES		

TYPE G
Two-piece fixed casting

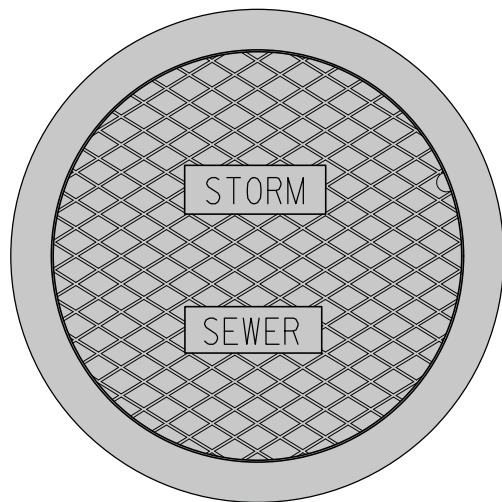

PLAN

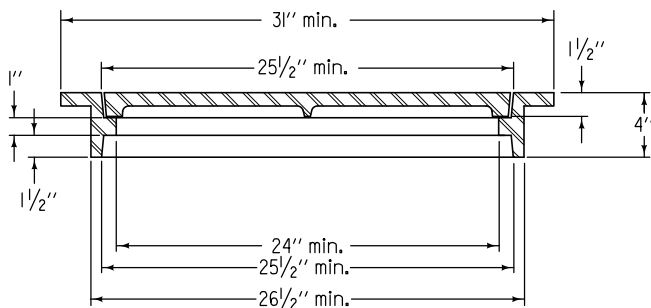



TYPICAL SECTION

FIGURE 6010.602 SHEET 2 OF 2

 SUDAS	 Iowa Department of Transportation	REVISION	
		2	04-15-14
FIGURE 6010.602	STANDARD ROAD PLAN	SW-602	
		SHEET 2 of 2	

REVISIONS: Changed dimensions on page 2.

 Paul D. Wigand
 SUDAS DIRECTOR
  Brian Smith
 DESIGN METHODS ENGINEER

**CASTINGS FOR
STORM SEWER MANHOLES**