

H IN FT.	CL - CL ABUT. BRG.		FOOTING SIZE	H IN FT.	CL - CL ABUT. BRG.		FOOTING SIZE
16 TO 18	160'-0		4' x 7' x 32'	37 TO 40	160'-0		4' x 8' x 36'
	180'-0		4' x 7' x 34'		180'-0		4' x 9' x 36'
	200'-0		4' x 8' x 34'		200'-0		4' x 9' x 38'
	220'-0		4' x 8' x 36'		240'-0		4' x 10' x 38'
	240'-0		4' x 9' x 36'		260'-0		4' x 10' x 40'
	280'-0		4' x 9' x 38'		340'-0		4' x 10' x 40'
19 TO 21	160'-0		4' x 7' x 32'	37 TO 40	160'-0		4' x 8' x 36'
	180'-0		4' x 7' x 34'		180'-0		4' x 9' x 36'
	200'-0		4' x 8' x 34'		200'-0		4' x 9' x 38'
	220'-0		4' x 8' x 36'		240'-0		4' x 10' x 38'
	240'-0		4' x 9' x 36'		260'-0		4' x 10' x 40'
	280'-0		4' x 9' x 38'		340'-0		4' x 10' x 40'
22 TO 24	160'-0		4' x 7' x 32'	37 TO 40	160'-0		4' x 8' x 36'
	180'-0		4' x 7' x 34'		180'-0		4' x 9' x 36'
	200'-0		4' x 8' x 34'		200'-0		4' x 9' x 38'
	220'-0		4' x 8' x 36'		240'-0		4' x 10' x 38'
	240'-0		4' x 9' x 36'		260'-0		4' x 10' x 40'
	280'-0		4' x 9' x 38'		340'-0		4' x 10' x 40'
25 TO 27	160'-0		4' x 7' x 32'	37 TO 40	160'-0		4' x 8' x 36'
	180'-0		4' x 7' x 34'		180'-0		4' x 9' x 36'
	200'-0		4' x 8' x 34'		200'-0		4' x 9' x 38'
	220'-0		4' x 8' x 36'		240'-0		4' x 10' x 38'
	240'-0		4' x 9' x 36'		260'-0		4' x 10' x 40'
	280'-0		4' x 9' x 38'		340'-0		4' x 10' x 40'
28 TO 30	160'-0		4' x 7' x 32'	37 TO 40	160'-0		4' x 8' x 36'
	180'-0		4' x 7' x 34'		180'-0		4' x 9' x 36'
	200'-0		4' x 8' x 34'		200'-0		4' x 9' x 38'
	220'-0		4' x 8' x 36'		240'-0		4' x 10' x 38'
	240'-0		4' x 9' x 36'		260'-0		4' x 10' x 40'
	280'-0		4' x 9' x 38'		340'-0		4' x 10' x 40'
31 TO 33	160'-0		4' x 7' x 32'	37 TO 40	160'-0		4' x 8' x 36'
	180'-0		4' x 7' x 34'		180'-0		4' x 9' x 36'
	200'-0		4' x 8' x 34'		200'-0		4' x 9' x 38'
	220'-0		4' x 8' x 36'		240'-0		4' x 10' x 38'
	240'-0		4' x 9' x 36'		260'-0		4' x 10' x 40'
	280'-0		4' x 9' x 38'		340'-0		4' x 10' x 40'
34 TO 36	160'-0		4' x 7' x 32'	37 TO 40	160'-0		4' x 8' x 36'
	180'-0		4' x 7' x 34'		180'-0		4' x 9' x 36'
	200'-0		4' x 8' x 34'		200'-0		4' x 9' x 38'
	220'-0		4' x 8' x 36'		240'-0		4' x 10' x 38'
	240'-0		4' x 9' x 36'		260'-0		4' x 10' x 40'
	280'-0		4' x 9' x 38'		340'-0		4' x 10' x 40'

FOOTING SIZE	REINFORCING STEEL (ONE FOOTING)				TOTAL WEIGHT (LB.)	STRUCTURAL CONCRETE (CY)
	BAR	NO., SIZE & SPACING	LENGTH	WEIGHT (LB.)		
4' x 7' x 32'	d2	74 - #9 AS SHOWN	9'-11"	2495	3602	33.2
	f1	32 - #5 @ 1'-0"	6'-8"	223		
	f2	7 - #5 @ 1'-0"	31'-8"	231		
	g1	32 - #6 @ 1'-0"	6'-8"	320		
	g2	7 - #6 @ 1'-0"	31'-8"	333		
	d2	74 - #9 AS SHOWN	9'-11"	2495		
4' x 7' x 34'	d2	74 - #9 AS SHOWN	9'-11"	2495	3772	35.3
	f1	34 - #5 @ 1'-0"	6'-8"	236		
	f2	7 - #5 @ 1'-0"	33'-8"	246		
	g1	34 - #6 @ 1'-0"	6'-8"	340		
	g2	9 - #6 @ 0'-9 1/2"	33'-8"	455		
	d2	74 - #9 AS SHOWN	9'-11"	2495		
4' x 8' x 34'	d2	74 - #9 AS SHOWN	9'-11"	2495	3946	40.3
	f1	34 - #5 @ 1'-0"	7'-8"	272		
	f2	8 - #5 @ 1'-0"	33'-8"	281		
	g1	34 - #6 @ 1'-0"	7'-8"	392		
	g2	10 - #6 @ 0'-10"	33'-8"	506		
	d2	74 - #9 AS SHOWN	9'-11"	2495		
4' x 8' x 36'	d2	74 - #9 AS SHOWN	9'-11"	2495	4444	42.7
	f1	36 - #5 @ 1'-0"	7'-8"	288		
	f2	8 - #5 @ 1'-0"	35'-8"	298		
	g1	36 - #6 @ 1'-0"	7'-8"	415		
	g2	13 - #7 @ 0'-7 1/2"	35'-8"	948		
	d2	74 - #9 AS SHOWN	9'-11"	2495		
4' x 9' x 36'	d2	74 - #9 AS SHOWN	9'-11"	2495	4776	48.0
	f1	36 - #5 @ 1'-0"	8'-8"	325		
	f2	10 - #5 @ 1'-0"	35'-8"	335		
	g1	44 - #6 @ 0'-9 1/2"	8'-8"	573		
	g2	11 - #8 @ 0'-10"	35'-8"	1048		
	d2	74 - #9 AS SHOWN	9'-11"	2495		
4' x 9' x 38'	d2	74 - #9 AS SHOWN	9'-11"	2495	5413	50.7
	f1	38 - #5 @ 1'-0"	8'-8"	343		
	f2	9 - #5 @ 1'-0"	37'-8"	354		
	g1	47 - #6 @ 0'-9 1/2"	8'-8"	612		
	g2	16 - #8 @ 0'-6 1/2"	37'-8"	1609		
	d2	74 - #9 AS SHOWN	9'-11"	2495		
4' x 10' x 38'	d2	74 - #9 AS SHOWN	9'-11"	2495	5910	56.3
	f1	38 - #5 @ 1'-0"	9'-8"	383		
	f2	10 - #5 @ 1'-0"	37'-8"	393		
	g1	47 - #7 @ 0'-9 1/2"	9'-8"	929		
	g2	17 - #8 @ 0'-7"	37'-8"	1710		
	d2	74 - #9 AS SHOWN	9'-11"	2495		
4' x 10' x 40'	d2	74 - #9 AS SHOWN	9'-11"	2495	6593	59.3
	f1	40 - #5 @ 1'-0"	9'-8"	403		
	f2	10 - #5 @ 1'-0"	39'-8"	414		
	g1	50 - #7 @ 0'-9 1/2"	9'-8"	988		
	g2	17 - #9 @ 0'-7"	39'-8"	2293		
	d2	74 - #9 AS SHOWN	9'-11"	2495		

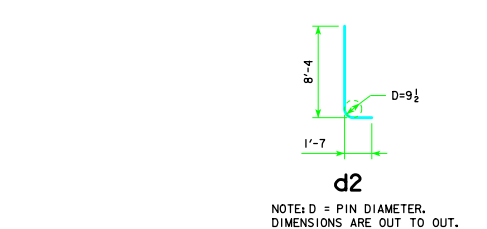
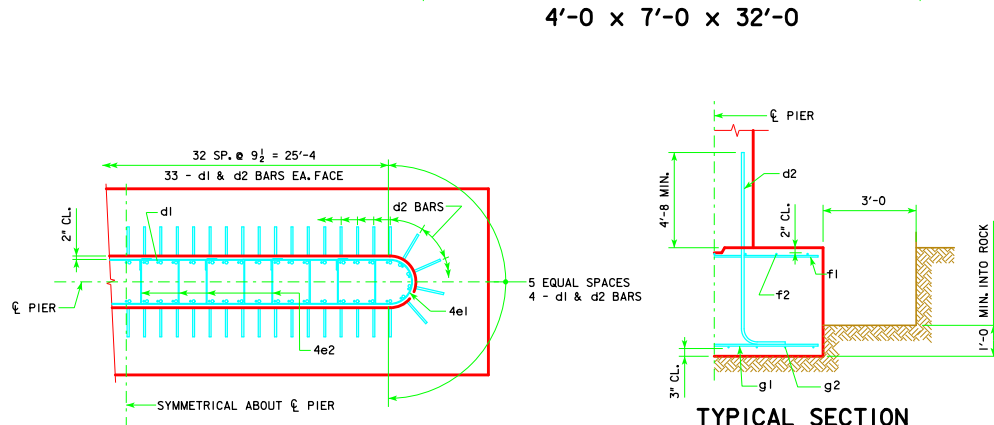
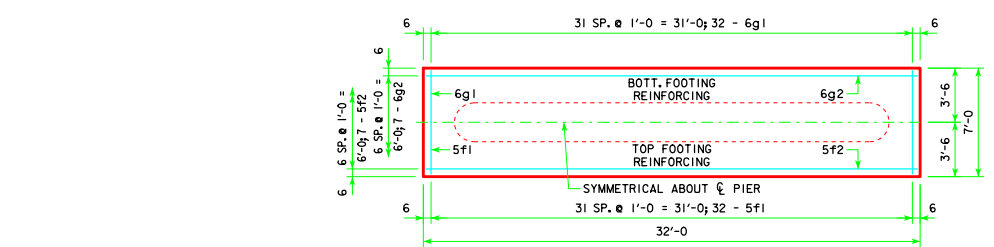

NOTE: D = PIN DIAMETER. DIMENSIONS ARE OUT TO OUT.

FOOTING NOTES:

THESE SPREAD FOOTINGS ARE DESIGNED AND DETAILED TO BE USED WITH THE CAP AND COLUMN DETAILS OF THE TEE PIERS AS SHOWN ON SHEET RS40-156-10.

THESE SPREAD FOOTINGS SHALL EXTEND AT LEAST 12 INCHES INTO SUITABLE FOUNDATION ROCK AND THE LAST 12 INCHES OF ROCK EXCAVATION SHALL BE TO NEAT LINES OF MASONRY. THE FOUNDATION ROCK SHALL HAVE A MINIMUM LRFD NOMINAL BEARING RESISTANCE OF 30 KIPS PER SQUARE FOOT (ALLOWABLE BEARING VALUE OF AT LEAST 10 KIPS PER SQUARE FOOT).

LATEST REVISION DATE 05-13	APPROVED BY <i>Thomas E. McQuinn</i> BRIDGE ENGINEER		STANDARD DESIGN - 40' ROADWAY, 3 SPAN BRIDGES
			ROLLED STEEL BEAM BRIDGES
			JUNE, 2010
TEE PIER - SPREAD FOOTINGS		RS40-164-10	
45° SKEW - SHEET 1			