

REVISED 09-14 - CHANGED REFERENCE TO THE BARRIER RAIL & OPEN RAIL TO THE J44-14 STANDARDS INSTEAD OF J44-06 STANDARDS.

BILL OF REINFORCING STEEL FOR SUPERSTRUCTURE - 80' BRIDGE

LOCATION	SKEW	SHAPE	0°				15°				30°				45°						
			BAR NO.	LENGTH	WEIGHT		BAR NO.	LENGTH	WEIGHT		BAR NO.	LENGTH	WEIGHT		BAR NO.	LENGTH	WEIGHT				
SLAB LONGITUDINAL BOTTOM			8a1	58	18'-3	2827	58	18'-3	2827	58	18'-3	2827	58	18'-3	2827	58	18'-3	2827	58	18'-3	2827
SLAB LONGITUDINAL BOTTOM			8a2	58	27'-0	4182	58	27'-0	4182	58	27'-0	4182	58	27'-0	4182	58	27'-0	4182	58	27'-0	4182
SLAB LONGITUDINAL BOTTOM			8a3	58	28'-0	4337	58	28'-0	4337	58	28'-0	4337	58	28'-0	4337	58	28'-0	4337	58	28'-0	4337
SLAB LONGITUDINAL BOTTOM			7a4	58	23'-0	2727	58	23'-0	2727	58	23'-0	2727	58	23'-0	2727	58	23'-0	2727	58	23'-0	2727
SLAB LONGITUDINAL BOTTOM			7a5	29	24'-6	1453	29	24'-6	1453	29	24'-6	1453	29	24'-6	1453	29	24'-6	1453	29	24'-6	1453
SLAB LONGITUDINAL BOTTOM, AT RAIL			7a6	8	28'-9	471	8	28'-9	471	8	28'-9	471	8	28'-9	471	8	28'-9	471	8	28'-9	471
SLAB LONGITUDINAL BOTTOM, AT RAIL			7a7	4	29'-4	240	4	29'-4	240	4	29'-4	240	4	29'-4	240	4	29'-4	240	4	29'-4	240
SLAB LONGITUDINAL BOTTOM, AT RAIL			8a8	8	20'-9	444	8	20'-9	444	8	20'-9	444	8	20'-9	444	8	20'-9	444	8	20'-9	444
SLAB LONGITUDINAL BOTTOM, AT RAIL			8a9	4	25'-6	273	4	25'-6	273	4	25'-6	273	4	25'-6	273	4	25'-6	273	4	25'-6	273
SLAB LONGITUDINAL TOP			6b1	58	19'-6	1699	58	19'-6	1699	58	19'-6	1699	58	19'-6	1699	58	19'-6	1699	58	19'-6	1699
SLAB LONGITUDINAL TOP			9b2	58	21'-9	4290	58	21'-9	4290	58	21'-9	4290	58	21'-9	4290	58	21'-9	4290	58	21'-9	4290
SLAB LONGITUDINAL TOP			9b3	58	32'-0	6311	58	32'-0	6311	58	32'-0	6311	58	32'-0	6311	58	32'-0	6311	58	32'-0	6311
SLAB LONGITUDINAL TOP			6b4	58	7'-6	654	58	7'-6	654	58	7'-6	654	58	7'-6	654	58	7'-6	654	58	7'-6	654
SLAB LONGITUDINAL TOP			8b5	58	21'-3	3291	58	21'-3	3291	58	21'-3	3291	58	21'-3	3291	58	21'-3	3291	58	21'-3	3291
SLAB LONGITUDINAL TOP			6b6	29	16'-4	712	29	16'-4	712	29	16'-4	712	29	16'-4	712	29	16'-4	712	29	16'-4	712
SLAB LONGITUDINAL TOP, AT RAIL			6b8	8	25'-6	307	8	25'-6	307	8	25'-6	307	8	25'-6	307	8	25'-6	307	8	25'-6	307
SLAB LONGITUDINAL TOP, AT RAIL			9b9	8	23'-6	640	8	23'-6	640	8	23'-6	640	8	23'-6	640	8	23'-6	640	8	23'-6	640
SLAB LONGITUDINAL TOP, AT RAIL			8b10	8	34'-0	727	8	34'-0	727	8	34'-0	727	8	34'-0	727	8	34'-0	727	8	34'-0	727
SLAB TRANSVERSE BOTTOM			6c1	77	25'-5	2940	77	26'-4	3046	66	25'-5	2520	56	25'-5	2138	59	23'-3	2061			
SLAB TRANSVERSE ENDS, BOTTOM			6c3	77	23'-3	2689	77	24'-1	2786	68	23'-3	2375	59	23'-3	2061						
SLAB TRANSVERSE ENDS, BOTTOM			6c4	-	-	-	-	-	-	14	VARIES	303	22	VARIES	485						
SLAB TRANSVERSE ENDS, BOTTOM			6c5	-	-	-	-	-	-	12	VARIES	255	22	VARIES	458						
SLAB TRANSVERSE ENDS, BOTTOM			6c6	-	-	-	-	-	-	12	VARIES	208	20	VARIES	366						
SLAB TRANSVERSE TOP			5d1	77	25'-9	2069	77	26'-8	2142	66	25'-9	1773	56	25'-9	1505						
SLAB TRANSVERSE TOP			5d2	77	23'-3	1868	77	24'-1	1935	68	23'-3	1649	59	23'-3	1431						
SLAB TRANSVERSE ENDS, TOP			5d3	-	-	-	-	-	-	14	VARIES	210	22	VARIES	337						
SLAB TRANSVERSE ENDS, TOP			5d4	-	-	-	-	-	-	12	VARIES	177	22	VARIES	318						
SLAB TRANSVERSE ENDS, TOP			5d5	-	-	-	-	-	-	12	VARIES	144	20	VARIES	254						
SLAB TRANSVERSE ENDS, TOP			5d6	-	-	-	-	-	-	12	VARIES	158	19	VARIES	261						
SLAB, TRANSVERSE AT ABUTMENT			8e1	18	28'-4	1362	18	29'-2	1402	18	31'-9	1526	18	37'-6	1803						
SLAB, TRANSVERSE AT ABUTMENT			8e2	18	23'-4	1122	18	24'-1	1158	18	26'-9	1286	18	32'-5	1558						
SLAB, HAIRPINS, AT ABUTMENT			6e3	100	5'-0	751	100	5'-1	764	100	5'-5	814	100	6'-1	914						
SLAB, DIAGONALS, AT ABUTMENT			6e4	100	5'-11	889	100	5'-11	889	100	5'-11	889	100	5'-11	889						
PIER CAP HOOPS			5h1	72	7'-1	532	72	7'-1	532	90	7'-1	665	108	7'-1	798						
PIER CAP ENDS			8h2	4	14'-5	154	4	14'-5	154	4	14'-5	154	4	14'-5	154						
PIER CAP, BOTTOM LONGITUDINAL			8h3	8	27'-5	586	8	28'-8	613	8	31'-8	677	8	37'-10	809						
PIER CAP, BOTTOM LONGITUDINAL			8h4	8	21'-11	469	8	22'-4	478	8	24'-6	524	8	29'-8	634						
PIER CAP, TOP LONGITUDINAL			8h5	4	28'-2	301	4	29'-6	316	4	32'-8	349	4	38'-11	416						
PIER CAP, TOP LONGITUDINAL			8h6	4	23'-5	251	4	23'-11	256	4	26'-3	281	4	31'-6	337						
TOP OF SLAB, TRANSVERSE, AT RAIL			5j1	152	8'-6	1348	152	8'-6	1348	146	8'-6	1295	144	8'-6	1277						
WING, VERTICAL			5m1	40	4'-5	185	40	4'-5	185	40	4'-5	185	40	4'-5	185						
WING, HORIZONTAL BACK FACE			5n1	24	6'-8	167	24	6'-8	167	24	6'-8	167	24	6'-8	167						
WING, HORIZONTAL TRAFFIC FACE			5n3	24	6'-9	169	24	6'-9	169	24	6'-9	169	24	6'-9	169						
SUB EPOXY COATED TOTAL - LBS.						53,437			53,925			54,565			55,685						
BARRIER RAIL - SEE LIST ON RAIL SHEET J44-46-14						3571			3571			3571			3571						
OPEN RAIL - SEE LIST ON RAIL SHEET J44-49-14						3725			3725			3725			3725						
EPOXY COATED RAIL TOTAL - LBS.						57,008			57,496			58,136			59,256						
WITH MONOLITHIC PIER CAP						57,162			57,650			58,290			59,410						
WITH BARRIER RAIL																					
EPOXY COATED RAIL TOTAL - LBS. NON-MONOLITHIC PIER CAP						54,715			55,147			55,486			56,108						
SAME AS ABOVE EXCEPT ALL "h" BARS DELETED						54,869			55,301			55,640			56,262						
WITH BARRIER RAIL									1893			1893			1893						
WITH OPEN RAIL									2074			2074			2074						

ESTIMATED QUANTITIES FOR SUPERSTRUCTURE - 80' BRIDGE

ITEM	SKEW	WITH MONOLITHIC PIER CAP				WITH NON-MONOLITHIC PIER CAP																
		0°	15°	30°	45°	0°	15°	30°	45°													
WITH BARRIER RAIL																						
*STRUCTURAL CONCRETE (BRIDGE)	C.Y.	212.9	214.1	217.9	226.2	206.6	207.5	210.6	217.3													
REINF. STEEL EPOXY COATED	LBS.	57,008	57,496	58,136	59,256	54,715	55,147	55,486	56,108													
REINF. STEEL STAINLESS STEEL	LBS.	1893	1893	1893	1893	1893	1893	1893	1893													
CONCRETE BARRIER OR OPEN RAIL	LIN. FT.	182.0	182.2	182.9	184.5	182.0	182.2	182.9	184.5													
WITH OPEN RAIL																						
*STRUCTURAL CONCRETE (BRIDGE)	C.Y.	212.8	213.9	217.7	226.0	206.4	207.3	210.4	217.1													
REINF. STEEL EPOXY COATED	LBS.	57,162	57,650	58,290	59,410	54,869	55,301	55,640	56,262													
REINF. STEEL STAINLESS STEEL	LBS.	2074	2074	2074	2074	2074	2074	2074	2074													

* INCLUDES 4 WINGS @ 0.68 C.Y. EACH; EXCLUDES RAIL CONCRETE.

BENT BAR DETAILS

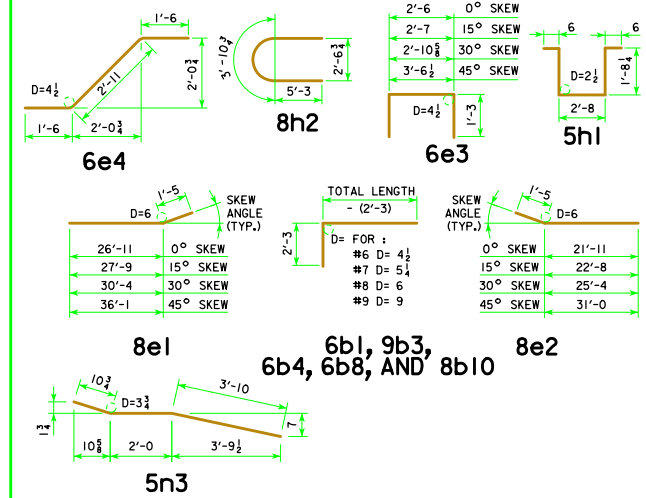

NOTE: ALL DIMENSIONS ARE OUT TO OUT. D = PIN DIAMETER.

NOTES:

ALL BARRIER RAIL REINFORCING STEEL IS TO BE EITHER EPOXY COATED OR STAINLESS STEEL AS SHOWN OR NOTED. THE STAINLESS STEEL REINFORCING STEEL SHALL BE DEFORMED BAR GRADE 60 MEETING THE REQUIREMENTS OF MATERIALS I.M.452.

ALL OTHER REINFORCING STEEL IS TO BE EPOXY COATED.

THE TRANSVERSE REBARS ARE DETAILED WITH A SPLICE LAP. AT THE CONTRACTOR'S OPTION, THIS LAP MAY BE ELIMINATED BY FURNISHING FULL LENGTH BARS WITH NO REDUCTION IN PAY WEIGHT FOR SAME.

09-14 LATEST REVISION DATE <i>Thomas E. M. Donnell</i> APPROVED BY BRIDGE ENGINEER	
	STANDARD DESIGN - 44' ROADWAY, 3 SPAN BRIDGES CONTINUOUS CONCRETE SLAB BRIDGES JULY, 2014
	SUPERSTRUCTURE DETAILS 80'-0 BRIDGE

J44-05-14