

REVISED 09-14 - CHANGED REFERENCE TO THE BARRIER RAIL & OPEN RAIL TO THE J40-14 STANDARDS INSTEAD OF J40-06 STANDARDS.

BILL OF REINFORCING STEEL FOR SUPERSTRUCTURE - 150' BRIDGE

LOCATION	SKEW	SHAPE	0°				15°				30°				45°						
			NO.	LENGTH	WEIGHT		NO.	LENGTH	WEIGHT		NO.	LENGTH	WEIGHT		NO.	LENGTH	WEIGHT				
SLAB LONGITUDINAL BOTTOM			10a1	53	32'-9	7469	53	32'-9	7469	53	32'-9	7469	53	32'-9	7469	53	32'-9	7469	53	32'-9	7469
SLAB LONGITUDINAL BOTTOM			10a2	53	51'-6	11,746	53	51'-6	11,746	53	51'-6	11,746	53	51'-6	11,746	53	51'-6	11,746	53	51'-6	11,746
SLAB LONGITUDINAL BOTTOM			10a3	53	48'-6	11,061	53	48'-6	11,061	53	48'-6	11,061	53	48'-6	11,061	53	48'-6	11,061	53	48'-6	11,061
SLAB LONGITUDINAL BOTTOM			904	52	36'-3	6409	52	36'-3	6409	52	36'-3	6409	52	36'-3	6409	52	36'-3	6409	52	36'-3	6409
SLAB LONGITUDINAL BOTTOM			905	26	45'-0	3978	26	45'-0	3978	26	45'-0	3978	26	45'-0	3978	26	45'-0	3978	26	45'-0	3978
SLAB LONGITUDINAL BOTTOM, AT RAIL			906	8	44'-7	1213	8	44'-7	1213	8	44'-7	1213	8	44'-7	1213	8	44'-7	1213	8	44'-7	1213
SLAB LONGITUDINAL BOTTOM, AT RAIL			907	8	13'-0	354	8	13'-0	354	8	13'-0	354	8	13'-0	354	8	13'-0	354	8	13'-0	354
SLAB LONGITUDINAL BOTTOM, AT RAIL			908	4	56'-8	771	4	56'-8	771	4	56'-8	771	4	56'-8	771	4	56'-8	771	4	56'-8	771
SLAB LONGITUDINAL BOTTOM, AT RAIL			10a9	8	37'-6	1291	8	37'-6	1291	8	37'-6	1291	8	37'-6	1291	8	37'-6	1291	8	37'-6	1291
SLAB LONGITUDINAL BOTTOM, AT RAIL			10a10	4	35'-0	603	4	35'-0	603	4	35'-0	603	4	35'-0	603	4	35'-0	603	4	35'-0	603
SLAB LONGITUDINAL TOP			6b1	53	7'-9	617	53	7'-9	617	53	7'-9	617	53	7'-9	617	53	7'-9	617	53	7'-9	617
SLAB LONGITUDINAL TOP			11b2	53	32'-9	9223	53	32'-9	9223	53	32'-9	9223	53	32'-9	9223	53	32'-9	9223	53	32'-9	9223
SLAB LONGITUDINAL TOP			11b3	53	28'-6	8026	53	28'-6	8026	53	28'-6	8026	53	28'-6	8026	53	28'-6	8026	53	28'-6	8026
SLAB LONGITUDINAL TOP			8b4	53	33'-2	4694	53	33'-2	4694	53	33'-2	4694	53	33'-2	4694	53	33'-2	4694	53	33'-2	4694
SLAB LONGITUDINAL TOP			11b5	52	30'-0	8289	52	30'-0	8289	52	30'-0	8289	52	30'-0	8289	52	30'-0	8289	52	30'-0	8289
SLAB LONGITUDINAL TOP			6b6	26	37'-4	1458	26	37'-4	1458	26	37'-4	1458	26	37'-4	1458	26	37'-4	1458	26	37'-4	1458
SLAB LONGITUDINAL TOP, AT RAIL			6b8	8	35'-0	421	8	35'-0	421	8	35'-0	421	8	35'-0	421	8	35'-0	421	8	35'-0	421
SLAB LONGITUDINAL TOP, AT RAIL			11b9	8	35'-6	1509	8	35'-6	1509	8	35'-6	1509	8	35'-6	1509	8	35'-6	1509	8	35'-6	1509
SLAB LONGITUDINAL TOP, AT RAIL			6b10	4	28'-0	169	4	28'-0	169	4	28'-0	169	4	28'-0	169	4	28'-0	169	4	28'-0	169
SLAB LONGITUDINAL TOP, AT RAIL			7b11	8	40'-9	667	8	40'-9	667	8	40'-9	667	8	40'-9	667	8	40'-9	667	8	40'-9	667
SLAB LONGITUDINAL TOP, AT RAIL			11b12	8	25'-6	1084	8	25'-6	1084	8	25'-6	1084	8	25'-6	1084	8	25'-6	1084	8	25'-6	1084
SLAB TRANSVERSE BOTTOM			6c1	147	23'-5	5171	147	24'-3	5355	138	23'-5	4854	128	23'-5	4502						
SLAB TRANSVERSE BOTTOM			6c2	147	21'-3	4692	147	22'-0	4858	139	21'-3	4437	131	21'-3	4182						
SLAB TRANSVERSE ENDS, BOTTOM			6c3	-	-	-	-	-	-	12	VARIES	223	20	VARIES	411						
SLAB TRANSVERSE ENDS, BOTTOM			6c4	-	-	-	-	-	-	11	VARIES	219	20	VARIES	386						
SLAB TRANSVERSE ENDS, BOTTOM			6c5	-	-	-	-	-	-	11	VARIES	176	18	VARIES	302						
SLAB TRANSVERSE ENDS, BOTTOM			6c6	-	-	-	-	-	-	11	VARIES	190	17	VARIES	311						
SLAB TRANSVERSE TOP			5d1	147	23'-9	3642	147	24'-7	3770	139	23'-9	3444	128	23'-9	3171						
SLAB TRANSVERSE TOP			5d2	147	21'-3	3259	147	22'-0	3374	139	21'-3	3081	131	21'-3	2904						
SLAB TRANSVERSE ENDS, TOP			5d3	-	-	-	-	-	-	12	VARIES	155	20	VARIES	286						
SLAB TRANSVERSE ENDS, TOP			5d4	-	-	-	-	-	-	11	VARIES	152	20	VARIES	268						
SLAB TRANSVERSE ENDS, TOP			5d5	-	-	-	-	-	-	11	VARIES	122	18	VARIES	210						
SLAB TRANSVERSE ENDS, TOP			5d6	-	-	-	-	-	-	11	VARIES	132	17	VARIES	216						
SLAB TRANSVERSE AT ABUTMENT			8e1	18	26'-4	1266	18	27'-1	1302	18	29'-6	1418	18	34'-8	1667						
SLAB TRANSVERSE AT ABUTMENT			8e2	18	21'-4	1026	18	22'-0	1058	18	24'-5	1174	18	29'-7	1422						
SLAB, HAIRPINS, AT ABUTMENT			6e3	92	5'-0	691	92	5'-1	703	92	5'-5	749	92	6'-1	841						
SLAB, DIAGONALS, AT ABUTMENT			6e4	92	5'-11	818	92	5'-11	818	92	5'-11	818	92	5'-11	818						
PIER CAP HOOPS			5h1	60	8'-6	532	60	8'-6	532	60	8'-6	532	60	8'-6	798						
PIER CAP ENDS			8h2	4	14'-5	154	4	14'-5	154	4	14'-5	154	4	14'-5	154						
PIER CAP, BOTTOM LONGITUDINAL			8h3	8	25'-5	543	8	26'-7	568	8	29'-4	627	8	35'-0	748						
PIER CAP, BOTTOM LONGITUDINAL			8h4	8	19'-11	426	8	20'-3	433	8	22'-2	474	8	26'-10	574						
PIER CAP, TOP LONGITUDINAL			8h5	4	26'-2	280	4	27'-5	293	4	30'-4	324	4	36'-1	386						
PIER CAP, TOP LONGITUDINAL			8h6	4	21'-5	229	4	21'-10	234	4	23'-11	256	4	28'-8	307						
TOP OF SLAB, TRANSVERSE, AT RAIL			5j1	292	8'-6	2589	292	8'-6	2589	282	8'-6	2501	276	8'-6	2447						
WING, VERTICAL			5m1	40	4'-5	185	40	4'-5	185	40	4'-5	185	40	4'-5	185						
WING, HORIZONTAL BACK FACE			5n1	24	6'-8	167	24	6'-8	167	24	6'-8	167	24	6'-8	167						
WING, HORIZONTAL TRAFFIC FACE			5n3	24	6'-9	169	24	6'-9	169	24	6'-9	169	24	6'-9	169						
SUB EPOXY COATED TOTAL - LBS.						106,891			107,614			107,785			108,884						
BARRIER RAIL - SEE LIST ON RAIL SHEET J40-46-14						5795			5795			5795			5795						
OPEN RAIL - SEE LIST ON RAIL SHEET J40-49-14						6338			6338			6338			6338						
EPOXY COATED RAIL TOTAL - LBS.			WITH MONOLITHIC PIER CAP			112,686			113,409			113,580			114,679						
			WITH BARRIER RAIL			113,229			113,952			114,123			115,222						
EPOXY COATED RAIL TOTAL - LBS.			WITH BARRIER RAIL			110,522			111,195			111,213			111,712						
SAME AS ABOVE EXCEPT ALL "h" BARS DELETED			WITH OPEN RAIL			111,065			111,738			111,756			112,255						
STAINLESS STEEL RAIL TOTAL - LBS.			WITH BARRIER RAIL			3366			3366			3366			3366						
			WITH OPEN RAIL			3267			3267			3267			3267						

ESTIMATED QUANTITIES FOR SUPERSTRUCTURE - 150' BRIDGE

ITEM	SKEW	WITH MONOLITHIC PIER CAP				WITH NON-MONOLITHIC PIER CAP			
		0°	15°	30°	45°	0°	15°	30°	45°
WITH BARRIER RAIL	*STRUCTURAL CONCRETE (BRIDGE) C.Y.	508.8	509.8	512.8	519.5	502.8	503.5	505.9	511.1
	REINF. STEEL EPOXY COATED LBS.	112,686	113,409	113,580	114,679	110,522	111,195	111,213	111,712
	REINF. STEEL STAINLESS STEEL LBS.	3366	3366	3366	3366	3366	3366	3366	3366
CONCRETE BARRIER OR OPEN RAIL	LIN. FT.	322.0	322.2	322.9	324.5	322.0	322.2	322.9	324.5
WITH OPEN RAIL	*STRUCTURAL CONCRETE (BRIDGE) C.Y.	508.6	509.5	512.5	519.2	502.5	503.2	505.6	510.8
	REINF. STEEL EPOXY COATED LBS.	113,229	113,952	114,123	115,222	111,065	111,738	111,756	112,255
	REINF. STEEL STAINLESS STEEL LBS.	3267	3267	3267	3267	3267	3267	3366	3267

* INCLUDES 4 WINGS @ 0.6 C.Y. EACH; EXCLUDES RAIL CONCRETE.

BENT BAR DETAILS

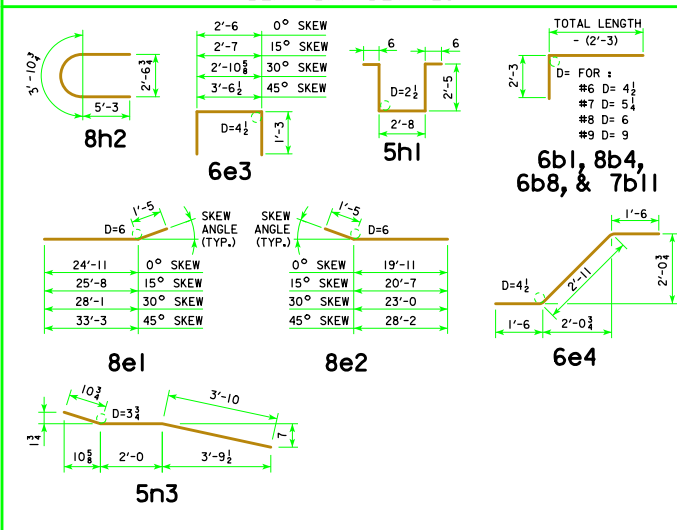

NOTES:

ALL BARRIER RAIL REINFORCING STEEL IS TO BE EITHER EPOXY COATED OR STAINLESS STEEL AS SHOWN OR NOTED. THE STAINLESS STEEL REINFORCING STEEL SHALL BE DEFORMED BAR GRADE 60 MEETING THE REQUIREMENTS OF MATERIALS I.M.452.

ALL OTHER REINFORCING STEEL IS TO BE EPOXY COATED.

THE TRANSVERSE REBARS ARE DETAILED WITH A SPLICE LAP. AT THE CONTRACTOR'S OPTION, THIS LAP MAY BE ELIMINATED BY FURNISHING FULL LENGTH BARS WITH NO REDUCTION IN PAY WEIGHT FOR SAME.

09-14 LATEST REVISION DATE <i>Thomas E. McQuillan</i> APPROVED BY BRIDGE ENGINEER	
	STANDARD DESIGN - 40' ROADWAY, 3 SPAN BRIDGES CONTINUOUS CONCRETE SLAB BRIDGES JULY, 2014
	<div style="text-align: center;"> SUPERSTRUCTURE DETAILS 150'-0 BRIDGE </div> <div style="text-align: right;"> J40-19-14 </div>