

**BILL OF REINFORCING STEEL - ONE ABUTMENT - 0° SKEW**

BRIDGE LENGTH		QUANTITY															
MARK	LOCATION	SHAPE	LENGTH	70'-0"	80'-0"	90'-0"	100'-0"	110'-0"	120'-0"	130'-0"	140'-0"	150'-0"	NO.		WEIGHT		
8r1	ABUTMENT FOOTING LONGITUDINAL	▬	28'-4"	7	530	7	530	7	530	7	530	7	530	7	530	7	530
8r2	ABUTMENT FOOTING LONGITUDINAL	▬	23'-4"	7	436	7	436	7	436	7	436	7	436	7	436	7	436
5s1	ABUTMENT FOOTING HOOPS	⏏	11'-0"	40	459	44	505	44	505	37	425	40	459	43	493	34	390
5s2	ABUTMENT FOOTING HOOPS	⏏	11'-0"	40	459	44	505	44	505	37	425	40	459	43	493	34	390
6+1	FOOTING TO SLAB DOWELS	▬	5'-0"	50	376	50	376	50	376	50	376	50	376	50	376	50	376
6+2	FOOTING TO SLAB DOWELS	▬	5'-7"	50	419	50	419	50	419	50	419	50	419	50	419	50	419
#2	PILE SPIRAL	⌀	38'-6"	10	64	11	71	11	71	12	77	13	84	13	84	14	90
	SPIRAL SPACERS, L <sub>1/2</sub> "x <sub>1/2</sub> "x <sub>1/2</sub> " 0.70	▬	1'-10"	30	39	33	42	33	42	36	46	39	50	39	50	42	54
REINFORCING STEEL EPOXY COATED - TOTAL (LBS.)				2323	2379	2379	2309	2354	2354	2398	2316	2348					

**BILL OF REINFORCING STEEL - ONE ABUTMENT - 15° SKEW**

BRIDGE LENGTH		QUANTITY															
MARK	LOCATION	SHAPE	LENGTH	70'-0"	80'-0"	90'-0"	100'-0"	110'-0"	120'-0"	130'-0"	140'-0"	150'-0"	NO.		WEIGHT		
8r1	ABUTMENT FOOTING LONGITUDINAL	▬	29'-2"	7	545	7	545	7	545	7	545	7	545	7	545	7	545
8r2	ABUTMENT FOOTING LONGITUDINAL	▬	24'-1"	7	450	7	450	7	450	7	450	7	450	7	450	7	450
5s1	ABUTMENT FOOTING HOOPS	⏏	11'-0"	45	516	40	459	40	459	44	505	36	413	36	413	39	447
5s2	ABUTMENT FOOTING HOOPS	⏏	11'-3"	4	47	4	47	4	47	4	47	4	47	4	47	4	47
6+1	FOOTING TO SLAB DOWELS	▬	5'-0"	50	376	50	376	50	376	50	376	50	376	50	376	50	376
6+2	FOOTING TO SLAB DOWELS	▬	5'-7"	50	419	50	419	50	419	50	419	50	419	50	419	50	419
#2	PILE SPIRAL	⌀	38'-6"	10	64	11	71	11	71	12	77	13	84	13	84	14	90
	SPIRAL SPACERS, L <sub>1/2</sub> "x <sub>1/2</sub> "x <sub>1/2</sub> " 0.70	▬	1'-10"	30	39	33	42	33	42	36	46	39	50	39	50	42	54
REINFORCING STEEL EPOXY COATED - TOTAL (LBS.)				2456	2409	2409	2465	2384	2384	2428	2346	2378					

**BILL OF REINFORCING STEEL - ONE ABUTMENT - 30° SKEW**

BRIDGE LENGTH		QUANTITY															
MARK	LOCATION	SHAPE	LENGTH	70'-0"	80'-0"	90'-0"	100'-0"	110'-0"	120'-0"	130'-0"	140'-0"	150'-0"	NO.		WEIGHT		
8r1	ABUTMENT FOOTING LONGITUDINAL	▬	31'-9"	7	593	7	593	7	593	7	593	7	593	7	593	7	593
8r2	ABUTMENT FOOTING LONGITUDINAL	▬	26'-9"	7	500	7	500	7	500	7	500	7	500	7	500	7	500
5s1	ABUTMENT FOOTING HOOPS	⏏	11'-0"	50	574	50	574	44	505	44	505	48	551	39	447	42	482
5s2	ABUTMENT FOOTING HOOPS	⏏	11'-11"	4	50	4	50	4	50	4	50	4	50	4	50	4	50
6+1	FOOTING TO SLAB DOWELS	▬	5'-0"	50	376	50	376	50	376	50	376	50	376	50	376	50	376
6+2	FOOTING TO SLAB DOWELS	▬	5'-7"	50	419	50	419	50	419	50	419	50	419	50	419	50	419
#2	PILE SPIRAL	⌀	38'-6"	11	71	11	71	12	77	12	77	13	84	14	90	15	96
	SPIRAL SPACERS, L <sub>1/2</sub> "x <sub>1/2</sub> "x <sub>1/2</sub> " 0.70	▬	1'-10"	33	42	33	42	36	46	36	46	39	50	42	54	45	58
REINFORCING STEEL EPOXY COATED - TOTAL (LBS.)				2625	2625	2566	2566	2623	2529	2574	2663	2513					

**BILL OF REINFORCING STEEL - ONE ABUTMENT - 45° SKEW**

BRIDGE LENGTH		QUANTITY															
MARK	LOCATION	SHAPE	LENGTH	70'-0"	80'-0"	90'-0"	100'-0"	110'-0"	120'-0"	130'-0"	140'-0"	150'-0"	NO.		WEIGHT		
8r1	ABUTMENT FOOTING LONGITUDINAL	▬	37'-6"	7	701	7	701	7	701	7	701	7	701	7	701	7	701
8r2	ABUTMENT FOOTING LONGITUDINAL	▬	32'-5"	7	606	7	606	7	606	7	606	7	606	7	606	7	606
5s1	ABUTMENT FOOTING HOOPS	⏏	11'-0"	55	631	55	631	60	688	60	688	52	597	56	642	60	688
5s2	ABUTMENT FOOTING HOOPS	⏏	13'-6"	4	56	4	56	4	56	4	56	4	56	4	56	4	56
6+1	FOOTING TO SLAB DOWELS	▬	5'-0"	50	376	50	376	50	376	50	376	50	376	50	376	50	376
6+2	FOOTING TO SLAB DOWELS	▬	5'-7"	50	419	50	419	50	419	50	419	50	419	50	419	50	419
#2	PILE SPIRAL	⌀	38'-6"	12	77	12	77	13	84	13	84	14	90	15	96	16	103
	SPIRAL SPACERS, L <sub>1/2</sub> "x <sub>1/2</sub> "x <sub>1/2</sub> " 0.70	▬	1'-10"	36	46	36	46	39	50	39	50	42	54	45	58	48	62
REINFORCING STEEL EPOXY COATED - TOTAL (LBS.)				2912	2912	2980	2980	2899	2954	3011	2928	2928					

NOTE: THE PILE SPIRALS AND SPIRAL SPACERS ARE TO BE NON-COATED REINFORCING BUT MAY BE EPOXY COATED AT THE CONTRACTORS OPTION AND EXPENSE.

**ESTIMATED QUANTITIES - ONE ABUT. - 0° SKEW**

LOCATION	UNIT	QUANTITY									
BRIDGE LENGTH		70'-0"	80'-0"	90'-0"	100'-0"	110'-0"	120'-0"	130'-0"	140'-0"	150'-0"	
STRUCTURAL CONCRETE (BRIDGE)	C.Y.	15.1	15.1	15.1	15.0	14.9	14.9	14.9	14.8	14.8	
REINFORCING STEEL EPOXY COATED	LBS.	2323	2379	2379	2309	2354	2354	2398	2316	2348	
WOOD PILES (TREATED)	NO.	10	11	11	12	13	13	14	16	17	
PREBORE HOLES	FT.	-	-	-	-	-	-	-	160	170	

**ESTIMATED QUANTITIES - ONE ABUT. - 15° SKEW**

LOCATION	UNIT	QUANTITY									
BRIDGE LENGTH		70'-0"	80'-0"	90'-0"	100'-0"	110'-0"	120'-0"	130'-0"	140'-0"	150'-0"	
STRUCTURAL CONCRETE (BRIDGE)	C.Y.	15.7	15.7	15.7	15.6	15.5	15.5	15.5	15.4	15.3	
REINFORCING STEEL EPOXY COATED	LBS.	2456	2409	2409	2465	2384	2384	2428	2346	2378	
WOOD PILES (TREATED)	NO.	10	11	11	12	13	13	14	16	17	
PREBORE HOLES	FT.	-	-	-	-	-	-	-	160	170	

**ESTIMATED QUANTITIES - ONE ABUT. - 30° SKEW**

LOCATION	UNIT	QUANTITY									
BRIDGE LENGTH		70'-0"	80'-0"	90'-0"	100'-0"	110'-0"	120'-0"	130'-0"	140'-0"	150'-0"	
STRUCTURAL CONCRETE (BRIDGE)	C.Y.	17.6	17.6	17.5	17.5	17.4	17.4	17.3	17.2	17.2	
REINFORCING STEEL EPOXY COATED	LBS.	2625	2625	2566	2566	2623	2529	2574	2663	2513	
WOOD PILES (TREATED)	NO.	11	11	12	12	13	14	15	17	18	
PREBORE HOLES	FT.	-	-	-	-	-	-	-	170	180	

**ESTIMATED QUANTITIES - ONE ABUT. - 45° SKEW**

LOCATION	UNIT	QUANTITY									
BRIDGE LENGTH		70'-0"	80'-0"	90'-0"	100'-0"	110'-0"	120'-0"	130'-0"	140'-0"	150'-0"	
STRUCTURAL CONCRETE (BRIDGE)	C.Y.	21.6	21.6	21.5	21.5	21.5	21.4	21.3	21.2	21.2	
REINFORCING STEEL EPOXY COATED	LBS.	2912	2912	2980	2980	2899	2954	3011	2928	2928	
WOOD PILES (TREATED)	NO.	12	12	13	13	14	15	16	18	18	
PREBORE HOLES	FT.	-	-	-	-	-	-	-	180	180	

**BENT BAR DETAILS**

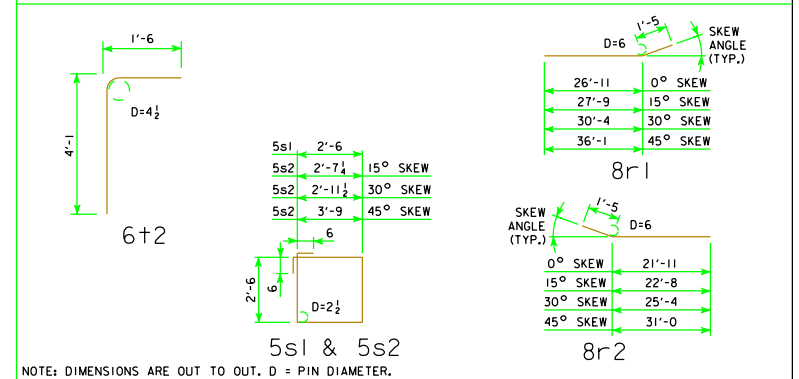

07-09 LATEST REVISION DATE	Approved by <i>Thomas C. McQuinn</i> APPROVED BY BRIDGE ENGINEER	
		STANDARD DESIGN - 44' ROADWAY, 3 SPAN BRIDGES <b>CONTINUOUS CONCRETE SLAB BRIDGES</b> NOVEMBER, 2006
		ABUTMENT DETAILS TIMBER PILING
		<b>J44-38-06</b>

REVISED 07-09 - CONCRETE QUANTITIES CHANGED.