

REVISED 09-14 - CORRECTED THE BARRIER RAIL REINFORCING STEEL QUANTITIES FOR ALL THE BRIDGE LENGTHS.

REINFORCING BAR LIST ONE SUPERSTRUCTURE AND TWO ABUTMENTS			BRIDGE LENGTH																				
			46'-8			55'-0			67'-6			80'-0			90'-0			100'-0			110'-0		
BAR	LOCATION	SHAPE	A		A		B		C		D		D		D		D						
NO.	LENGTH	WEIGHT	NO.	LENGTH	WEIGHT	NO.	LENGTH	WEIGHT	NO.	LENGTH	WEIGHT	NO.	LENGTH	WEIGHT	NO.	LENGTH	WEIGHT	NO.	LENGTH	WEIGHT			
6a1	SLAB TRANSVERSE, TOP & BOTTOM		131	32'-10	6461	153	32'-10	7546	187	32'-10	9223	221	32'-10	10,899	247	32'-10	12,181	273	32'-10	13,464	301	32'-10	14,845
5b1	SLAB LONGITUDINAL TOP & BOTTOM		168	25'-9	4513	168	29'-11	5242	168	36'-2	6337	252	29'-0	7622	252	32'-4	8498	252	35'-8	9374	252	39'-0	10,251
5d2	ABUTMENT DIAPHRAGM, LONGITUDINAL - F.F		24	6'-2	155	24	6'-2	155	24	5'-11	149	24	5'-11	149	24	6'-1	153	24	6'-1	153	24	6'-1	153
5d3	ABUTMENT DIAPHRAGM, LONGITUDINAL - F.F		8	5'-3	44	8	5'-3	44	8	5'-0	42	8	5'-0	42	8	4'-10	41	8	4'-10	41	8	4'-10	41
5d5	ABUTMENT DIAPHRAGM, LONGITUDINAL - END		12	4'-7	58	12	4'-7	58	12	4'-7	58	12	4'-7	58	12	4'-7	58	12	4'-7	58	12	4'-7	58
5d6	ABUTMENT DIAPHRAGM, LONGITUDINAL - B.F.		8	32'-9	274	8	32'-9	274	8	32'-9	274	8	32'-9	274	8	32'-9	274	8	32'-9	274	8	32'-9	274
5d7	PAVING NOTCH, LONGITUDINAL		4	32'-8	137	4	32'-8	137	4	32'-8	137	4	32'-8	137	4	32'-8	137	4	32'-8	137	4	32'-8	137
5d8	ABUTMENT DIAPH. WING EXT. LONGIT.		-	-	-	-	-	-	-	-	-	-	-	-	24	10'-9	269	24	10'-9	269	24	10'-9	269
5d9	ABUTMENT DIAPH. WING EXT. LONGIT.		-	-	-	-	-	-	-	-	-	24	10'-8	267	24	10'-8	267	24	10'-8	267	24	10'-8	267
8f1	ABUTMENT FOOTING LONGITUDINAL		18	32'-11	1582	18	32'-11	1582	18	32'-11	1582	18	32'-11	1582	18	32'-11	1582	18	32'-11	1582	18	32'-11	1582
8f3	ABUTMENT EXTENSION LONGITUDINAL		-	-	-	-	-	-	-	-	-	16	10'-2	435	16	10'-2	435	16	10'-2	435	16	10'-2	435
8f4	ABUTMENT EXTENSION LONGITUDINAL		-	-	-	-	-	-	-	-	-	16	8'-8	371	16	8'-8	371	16	8'-8	371	16	8'-8	371
8g1	ABUTMENT VERTICAL		114	6'-7	2004	114	6'-7	2004	114	7'-2	2181	110	7'-8	2252	110	8'-5	2472	110	8'-5	2472	110	8'-5	2472
8g3	ABUTMENT DIAPHRAGM VERTICAL - B.F.		50	15'-3	2036	50	15'-3	2036	50	15'-3	2036	50	15'-9	2103	50	15'-9	2103	50	15'-9	2103	50	15'-9	2103
6g4	ABUT. DIAPH. WING EXT. VERT.		-	-	-	-	-	-	-	-	-	40	5'-8	341	40	6'-5	386	40	6'-5	386	40	6'-5	386
5h1	ABUTMENT TO WING ANCHOR		28	6'-8	196	28	6'-8	196	28	6'-8	196	36	6'-8	252	36	6'-8	252	36	6'-8	252	36	6'-8	252
5h2	ABUTMENT TO WING ANCHOR		56	4'-11	288	56	4'-11	288	56	4'-11	288	12	4'-11	62	12	4'-11	62	12	4'-11	62	12	4'-11	62
5h3	ABUTMENT TO WING ANCHOR		28	6'-9	198	28	6'-9	198	28	6'-9	198	36	6'-9	256	36	6'-9	256	36	6'-9	256	36	6'-9	256
5h4	ABUTMENT TO WING ANCHOR		-	-	-	-	-	-	-	-	-	12	4'-11	62	12	4'-11	62	12	4'-11	62	12	4'-11	62
5j1	SLAB TRANSV. TOP AT RAIL		130	6'-3	848	152	6'-3	991	186	6'-3	1213	220	6'-3	1435	246	6'-3	1604	272	6'-3	1774	300	6'-3	1956
5k1	PAVING NOTCH, TRANSVERSE		54	4'-11	277	54	4'-11	277	54	4'-11	277	54	4'-11	277	54	4'-11	277	54	4'-11	277	54	4'-11	277
5k2	PAVING NOTCH, TRANSVERSE		54	3'-5	193	54	3'-5	193	54	3'-5	193	54	3'-5	193	54	3'-5	193	54	3'-5	193	54	3'-5	193
5p1	ABUTMENT HOOPS		120	10'-6	1314	120	10'-6	1314	108	10'-6	1183	104	10'-6	1139	120	10'-6	1315	104	10'-6	1139	104	10'-6	1139
5p2	ABUTMENT EXTENSIONS HOOPS		-	-	-	-	-	-	-	-	-	24	10'-8	268	24	10'-8	268	24	10'-8	268	24	10'-8	268
6p3	ABUT. BOT. AT PILES		-	-	-	-	-	-	-	-	-	28	6'-8	281	32	6'-8	321	36	6'-8	361	36	6'-8	361
5r1	PAVING BLOCK LIFTING HOOPS		8	2'-10	24	8	2'-10	24	8	2'-10	24	8	2'-10	24	8	2'-10	24	8	2'-10	24	8	2'-10	24
5s1	WING, VERTICAL		64	5'-10	390	64	5'-10	390	64	6'-2	412	64	6'-11	462	64	7'-8	512	64	7'-8	512	64	7'-8	512
4t1	UNDER BEAMS AT ABUTMENTS		10	4'-8	32	10	4'-8	32	10	4'-8	32	10	4'-8	32	10	4'-10	33	10	4'-10	33	10	4'-10	33
#2	PILE SPIRAL - NO. 2 BAR		10	38'-6	64	10	38'-6	64	12	38'-6	77	18	38'-6	115	20	38'-6	128	22	38'-6	141	22	38'-6	141
	SPIRAL SPACER L x 1/4 x 1/4 x 0.70		20	1'-10	27	20	1'-10	27	24	1'-10	32	36	1'-10	48	40	1'-10	53	44	1'-10	58	44	1'-10	58
	REINFORCING STEEL - (LBS.)				21115			23072			26144			31707			34587			36798			39238
	SEE BARRIER RAIL DETAILS (LBS.)				4054			4410			4968			6002			6438			6875			7353
	SEE OPEN RAIL DETAILS (LBS.)				4179			4572			5277			6816			7478			7900			8322

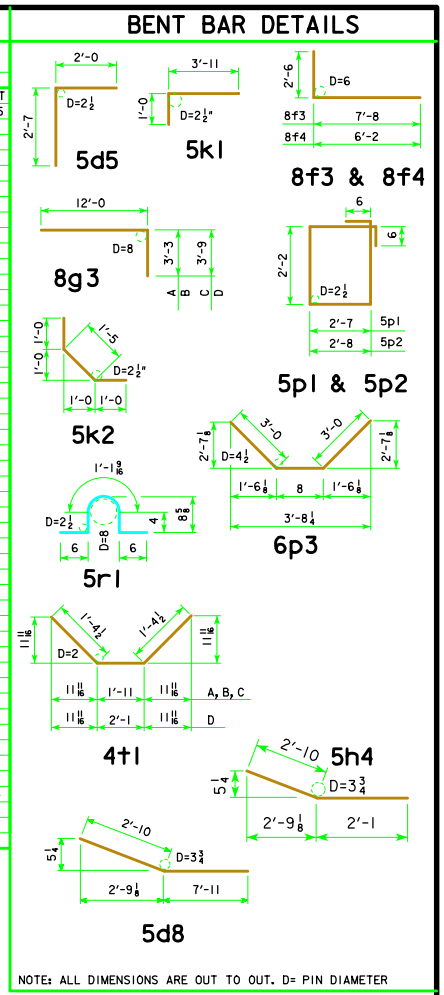

CONCRETE PLACEMENT QUANTITIES (SUPERSTRUCTURE PLUS INTEGRAL ABUTMENTS)			ESTIMATED QUANTITIES (SUPERSTRUCTURE PLUS INTEGRAL ABUTMENTS)															
SLAB, AND	WITH BARRIER RAIL	CU.YD.	46'-8	55'-0	67'-6	80'-0	90'-0	100'-0	110'-0	NO. OF STEEL H-PILES FOR TWO ABUTMENTS (HP10X57)	NO.	10	10	12	18	20	22	22
ABUT. DIAPHRAGM	WITH OPEN RAIL	CU.YD.	69.1	76.3	91.0	111.1	126.9	136.1	145.2	STRUCTURAL CONCRETE, (BRIDGE)	CU.YD.	104.4	111.6	126.7	155.4	172	181.2	190.3
PAVING BLOCKS		CU.YD.	1.5	1.5	1.5	1.5	1.5	1.5	1.5	WITH BARRIER RAIL	CU.YD.	105.9	113.3	128.8	157.9	174.7	184.3	193.7
ABUTMENT WINGS		CU.YD.	7.2	7.2	7.6	8.4	9.2	9.2	9.2	CONCRETE RAIL (BARRIER OR OPEN)	L.F.	127.3	144	169	214	234	254	274
ABUTMENT FOOTINGS		CU.YD.	26.6	26.6	26.6	34.4	34.4	34.4	34.4	WITH BARRIER RAIL	LBS.	24,969	27,282	30,912	37,500	40,816	43,464	46,382
										WITH OPEN RAIL	LBS.	25,294	27,644	31,421	38,523	42,065	44,698	47,560
										WITH BARRIER RAIL	LBS.	1480	1471	1515	1555	1642	1642	1642
										WITH OPEN RAIL	LBS.	1190	1180	1180	1180	1212	1212	1212

09-14
LATEST REVISION DATE

Thomas E. McQuill
APPROVED BY BRIDGE ENGINEER

STANDARD DESIGN - 30' ROADWAY, SINGLE SPAN BRIDGE

PRETENSIONED PRESTRESSED CONCRETE BEAM BRIDGES

APRIL, 2012

DECK & ABUTMENT REINF. H30SI-08-12

0° SKEW