

PERPENDICULAR RAMPS

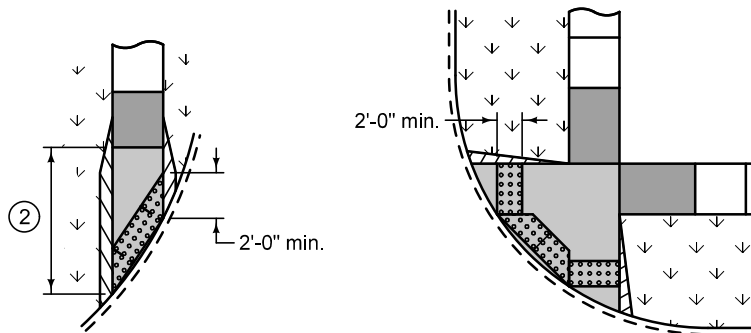

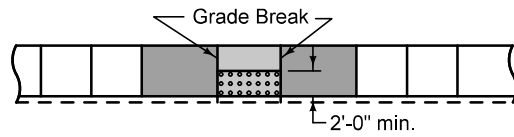

PARALLEL RAMPS

Provide a minimum 2 foot width of detectable warning surfaces in the direction of pedestrian travel across the full width of the curb ramp or turning space, exclusive of curbs or flares.

- ① When detectable warning is located on curb ramp surface, orient domes in the direction of pedestrian travel.
- ② When the distance between the grade break and the back of curb is less than 5 feet, place detectable warning surface at the bottom of the curb ramp.

Where one corner of the curb ramp is more than 5 feet from the back of curb, construct curb ramp as a parallel curb ramp. Move grade break back as required to place detectable warning on turning space at the back of curb.

Key

-  Curb Ramp
-  Turning Space
-  Detectable Warning

	REVISION
	New 10-16-12
	<b>7030.210</b>
SHEET 1 of 1	

SUDAS Standard Specifications

DETECTABLE WARNING PLACEMENT