

FRONT VIEW

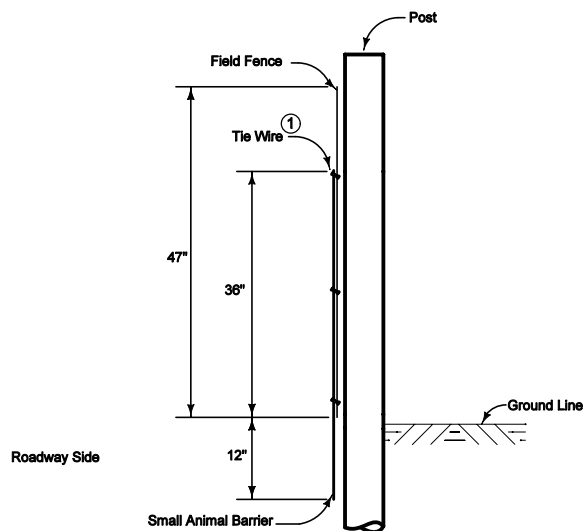

SIDE VIEW

Small Animal Barrier is used for preventing small mammals, reptiles and amphibians from migrating on to the highway right of way.

Contract item "Small Animal Barrier" includes chain link fence fabric, galvanized tie wires, 12 inch trench excavation, backfill and compaction around fence fabric, all materials, tools and labor required to construct barrier as detailed.

Construct Small Animal Barrier using 14 gage Chain Link Fence Fabric with a 1/2 inch grid Mesh spacing and a 48 inch total height. Use Chain Link Fabric per Standard Specification Section 4154 and install fencing per the Contract Documents.

Stretch Small Animal Barrier and mount on Field Fence using Galvanized Wire Ties and as described in Standard Specification Section 4154. Bury the bottom 12 inches of the Barrier below the finished grade to restrict burrowing under the barrier. Do not damage or deform the barrier fabric when backfilling and compacting trench material around the fabric. Overlap the ends of the barrier fabric roll a minimum of 6 inches and tie both ends to the Field Fence, leaving no gap between the fabric ends.

Measurement will be in linear feet of installed Small Animal Barrier and paid for at the contract unit price per linear feet.

- ① Place galvanized Tie Wires at the following three vertical locations: top of chain link fence fabric, bottom of field fence, approximate mid point between the top and bottom ties. Repeat attachment locations at 1'-6" intervals along the length of the barrier.

Possible Contract Items:  
 Field Fence  
 Field Fence Brace Panel  
 Small Animal Barrier

Possible Tabulation:  
 100-7

 <b>Iowa Department of Transportation</b> Highway Division		
<b>DETAIL SHEET</b>		<b>510-3</b>
REVISION: Changed woven wire fabric to chain link	REVISION NO. 1	REVISION DATE 04-20-10

SUPPLEMENTAL DETAILS  
 OF FIELD FENCE  
 (SMALL ANIMAL BARRIER)