

ANCHOR BOLT DETAILS

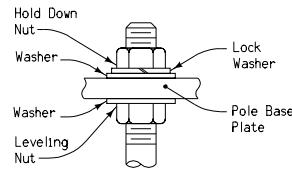

DETAIL 'A'
Without Transformer Base ⑤

HARDWARE CLASSIFICATION				
Bolt Size	Bolt Grade	Nuts (Heavy Hex)	Washers	Galvanizing
1" x Various Full Length Galvanized	ASTM F-1554 Grade 105 Class 2A	ASTM A-563-DH Class 2B	ASTM F-436	ASTM A-153 Class C

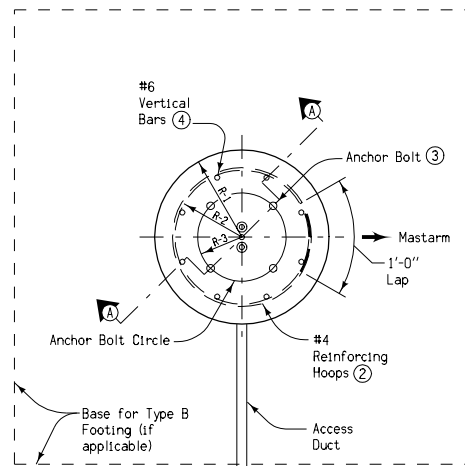

FOOTING PLAN

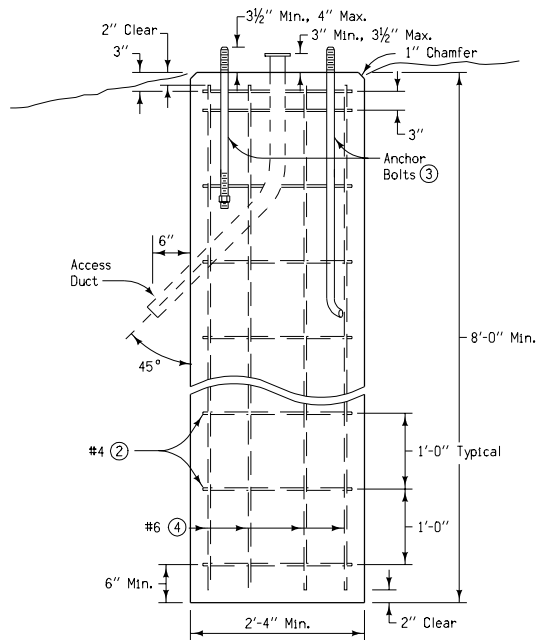

SECTION A-A
TYPE A FOOTING

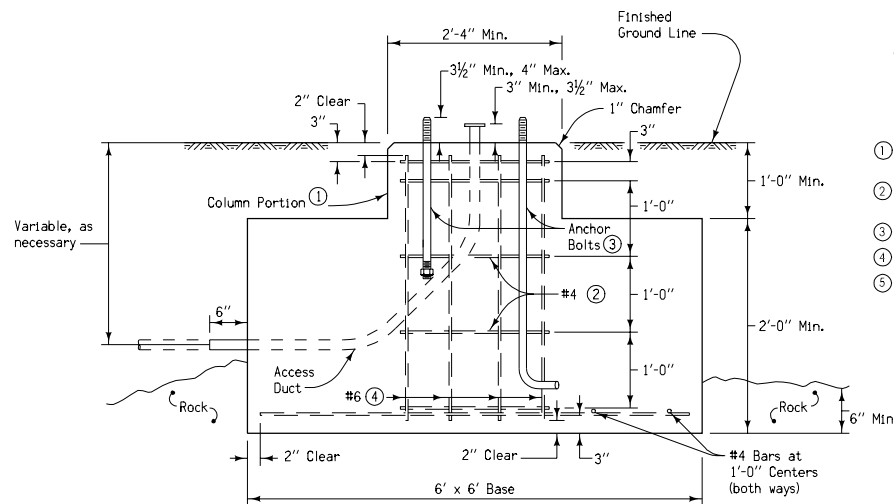

SECTION A-A
TYPE B FOOTING

The details indicated herein are for the construction of a concrete footing for light poles with a mounting height of 49 feet or less. Where poles with greater mounting heights are specified, footings of different design may be required.

The Type A Footing shall be the normally required footing construction. Where rock, shale, sandstone, broken or shattered rock, or other similar material is encountered, the Engineer may approve the use of the Type B Footing. All excavations shall be disposed in the area adjacent to the footing and shaped to the natural ground contour unless otherwise directed by the Engineer.

Diameter of footing is determined by the Anchor Bolt Circle required for the diameter of the pole being installed. Where dimensional requirements indicated cannot be met with normal footings, it shall be enlarged as necessary to accommodate the required diameter of the Contractor's expense.

R-1 Radius of the outside of the footing shall be 1' 1-1/2" minimum unless anchor bolt circle requires a larger radius.

R-2 Radius of the reinforcing hoop shall be a maximum of 2" less than R-1 and a minimum of 1" greater than R-3.

R-3 Radius of the anchor bolt circle.

Open ends of conduit shall be appropriately capped during construction to prevent infiltration of foreign material. After the cable is installed, the upper end of the ducts shall be sealed against entry of moisture by a method approved by the Engineer. The access ducts shall have a 2" Nominal Outside Diameter, with a minimum of two access ducts per footing unless otherwise specified. The ground wire duct shall have a 1" Nominal Outside Diameter.

No welding of the anchor bolts is permitted. The Contractor shall obtain a template from the light pole manufacturer for placement of anchor bolts.

- ① Footing base may be thickened and column portion omitted at the Contractor's option.
- ② Horizontal reinforcing hoops shall be #4 bars lapped a minimum of 1'-0" as indicated.
- ③ Either type of bolt shown may be used at the option of the Contractor.
- ④ This bar is to be a #7 when the mounting height is greater than 44 feet.
- ⑤ When transformer base is required, refer to Standard Road Plan RM-43.

 Iowa Department of Transportation	REVISION
	3 04-17-07
STANDARD ROAD PLAN	RM-39
	SHEET 1 of 1
REVISIONS: Added note covering anchor welding prohibition and template requirement. Renamed standard.	
<i>Deanna Mayfield</i> APPROVED BY DESIGN METHODS ENGINEER	

LIGHT POLE FOOTINGS