

CORRUGATED METAL PIPE

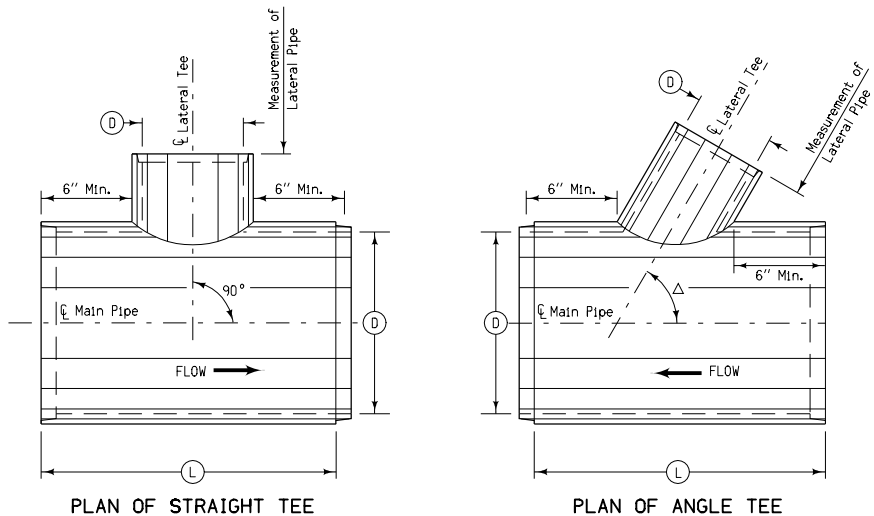

CONCRETE PIPE

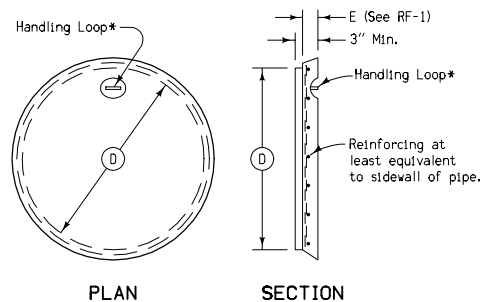

DETAILS OF CONCRETE PIPE CAP

GENERAL NOTES:

Tees may be required in any size from 12 inch diameter to 48 inch diameter (in 6 inch increments) on main pipe culverts equal to or greater in diameter than that of the tee. Angle tees may be required in any delta angle (of 5 degree increment) between 45 and 90 degrees. Unless a delta angle of other than 90 degrees is so specified in the detail project plans, tee sections shall be considered to be 90 degrees (straight tees).

Example: "18-36 inch Tee" means a 18 inch diameter 90 degree lateral tee attached to a 36 inch main pipe culvert.

Example: "24-48 inch 75 degree Tee" means a 24 inch diameter lateral tee attached to a 48 inch main pipe culvert at an angle of 75 degrees.

The fabrication of the tee shall be accomplished in such a manner as to be as free from obstruction on the inside of the pipe as is reasonable and otherwise to be constructed by methods approved by the Engineer.

CORRUGATED METAL PIPE TEE:

Any damage to protective coating resulting from installation of culvert shall be repaired as directed by the Engineer.

CONCRETE PIPE TEE:

Length of main pipe section (L) shall be a minimum of 4 feet and a maximum of 6 feet. Length of main pipe section shall be included in measured length of structure.

CONCRETE PIPE CAP:

The use of an approved pipe cap is required when so indicated on the detail project plans. The dimensions of the pipe cap shall be such as to neatly fit the groove end of the appropriate size of culvert pipe.

The cap may be precast or it may be cast directly into the pipe end with a tight mortar joint between the cap and the pipe. If the cap is positioned at the construction site, an approved bituminous joint material shall be placed between the cap and the pipe.

The Pipe Cap shall not be paid for directly, but when specified, shall be considered to be incidental to other pipe culvert work on the project.

<b>STANDARD ROAD PLAN</b>	
<b>RF-21</b>	
REVISION: Modify General Notes. No Longer a Bid Item.	REVISION NO. 4
<i>William J. Stein</i> APPROVED BY DESIGN METHODS ENGINEER	REVISION DATE 04-15-03

CULVERT PIPE TEE SECTIONS